

# INSTRUCTION MANUAL

*Fairmont*<sup>®</sup>

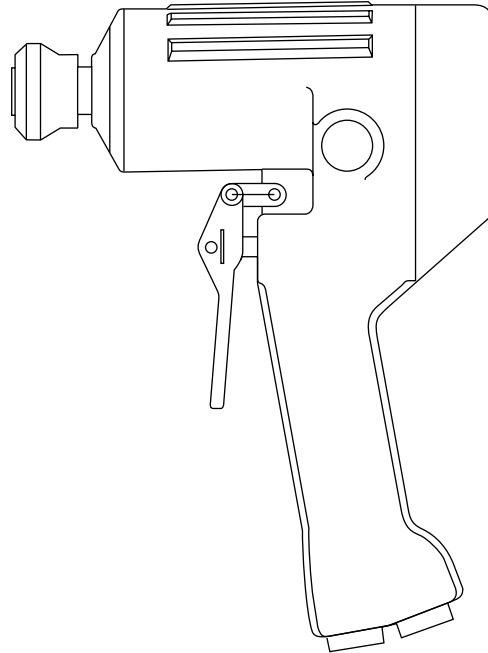

## **H8508**

# **Hydraulic Impact Wrench**

## **Models 48330 and 48329**

Serial Code FPB



**Read and understand** all of the instructions and safety information in this manual before operating or servicing this tool.

**Table of Contents**

Description .....	2
Safety .....	2
Purpose of this Manual .....	2
Other Publications .....	2
Important Safety Information .....	3-4
Identification .....	5
Specifications .....	6
Hoses and Fittings .....	7
Hose Connections .....	7
Operation .....	8-10
Maintenance .....	11
Troubleshooting .....	12-16
Disassembly .....	17-18
Assembly .....	18-20
Illustrations and Parts Lists .....	21-28
Models 48330/48329 (effective through serial number 299) .....	21-24
Models 48330/48329 (effective with serial number 300) .....	25-28
Accessories .....	29

**Description**

Fairmont Hydraulic Impact Wrenches are intended to be used to tighten nuts, install lag screws, or as a wood drill in most any utility or construction application. The trigger spool design contains a center spool that can be rotated to allow the impact wrench to be used with either an open-center or closed-center hydraulic system.

The lightweight 48330 Impact Wrench comes equipped with a standard 7/16" hex quick-change chuck for use with wood bits, or adapts to 1/2" square drive for use with sockets. The 48329 uses a standard 1/2" square drive.

The 48330 and 48329 also come equipped with a reversing spool, allowing the wrench to be operated in forward or reverse. The handle is heat-insulated for operator comfort and safety.

**Safety**

Safety is essential in the use and maintenance of Fairmont tools and equipment. This manual and any markings on the tool provide information for avoiding hazards and unsafe practices related to the use of this tool. Observe all of the safety information provided.

**Purpose of this Manual**

This manual is intended to familiarize all personnel with the safe operation and maintenance procedures for the following Fairmont tool:

H8508 Hydraulic Impact Wrench

Keep this manual available to all personnel.

Replacement manuals are available upon request at no charge.

**Other Publications****Tool Owners/Users**

SAE Standard J1273 (Hose and Hose Assemblies):  
Publication 999 3032.3

All specifications are nominal and may change as design improvements occur. Greenlee Textron Inc. shall not be liable for damages resulting from misapplication or misuse of its products.

**KEEP THIS MANUAL**

**IMPORTANT SAFETY INFORMATION**



**SAFETY ALERT SYMBOL**

This symbol is used to call your attention to hazards or unsafe practices which could result in an injury or property damage. The signal word, defined below, indicates the severity of the hazard. The message after the signal word provides information for preventing or avoiding the hazard.

**⚠ DANGER**

Immediate hazards which, if not avoided, WILL result in severe injury or death.

**⚠ WARNING**

Hazards which, if not avoided, COULD result in severe injury or death.

**⚠ CAUTION**

Hazards or unsafe practices which, if not avoided, MAY result in injury or property damage.



**⚠ WARNING**

Skin injection hazard:  
Oil under pressure easily punctures skin, causing serious injury, gangrene, or death. If you are injured by escaping oil, seek medical attention immediately.

- Do not use hands to check for leaks.
- Do not hold hose or couplers while the hydraulic system is pressurized.
- Depressurize the hydraulic system before servicing.

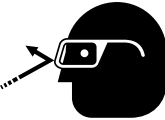

**⚠ WARNING**

Wear eye protection when operating or servicing this tool.

Failure to wear eye protection could result in serious eye injury from flying debris or hydraulic oil.

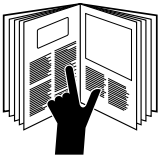

**⚠ WARNING**

Read and understand all of the instructions and safety information in this manual before operating or servicing this tool.

Failure to observe this warning could result in severe injury or death.



**⚠ WARNING**

Electric shock hazard:  
This tool is not insulated. When using this unit near energized electrical lines, use only certified nonconductive hoses and proper personal protective equipment.  
Failure to observe this warning could result in severe injury or death.

**⚠ WARNING**

- Keep all parts of the body away from rotating parts when the tool is in operation. Contact with moving parts can result in severe injury.
- Do not change accessories, inspect, adjust or clean tool when it is connected to a power source. Accidental start-up can result in serious injury.
- Maintain a firm grip on tool, using both hands at all times. Serious injury can result if an operator does not control the tool.
- Do not lock trigger in the power-ON position. Operator can not stop tool when trigger is locked.

Failure to observe these warnings could result in severe injury or death.

**⚠ WARNING**

- Use only impact style bits. Bits not designed for impact applications can break and cause severe injury.
- Use only sockets approved for impact use. Accessories not designed for impact applications can break and cause severe injury.
- Inspect drill bits and sockets before use. Discard damaged bits and sockets. Damaged accessories can break and cause severe injury.

**IMPORTANT SAFETY INFORMATION**

	<b>⚠ WARNING</b>
	<p>Tool and drill bit may be hot during and after operation. Contact with hot surfaces could result in serious injury.</p>

<b>⚠ WARNING</b>
<p>Do not exceed the following hydraulic power source maximums:</p> <ul style="list-style-type: none"> <li>• Hydraulic flow: 37.9 l/min (10 gpm).</li> <li>• Pressure relief: 138 bar (2000 psi).</li> <li>• Back pressure: 13.8 bar (200 psi).</li> </ul> <p>Failure to observe this warning could result in severe injury or death.</p>

<b>⚠ WARNING</b>
<p>Do not disconnect tool, hoses, or fittings while the power source is running or if the hydraulic fluid is hot. Hot hydraulic fluid could cause serious burns.</p>

<b>⚠ WARNING</b>
<p>Do not reverse hydraulic flow. Operation with hydraulic flow reversed can cause tool malfunction. Connect the pressure (supply) hose and tank (return) hose to the proper ports.</p> <p>Failure to observe this warning could result in severe injury or death.</p>

<b>⚠ CAUTION</b>
<p>Hydraulic oil can cause skin irritation.</p> <ul style="list-style-type: none"> <li>• Handle the tool and hoses with care to prevent skin contact with hydraulic oil.</li> <li>• In case of accidental skin contact with hydraulic oil, wash the affected area immediately to remove the oil.</li> </ul> <p>Failure to observe these precautions may result in injury.</p>

<b>⚠ CAUTION</b>
<ul style="list-style-type: none"> <li>• Wear protective gloves when handling, removing and installing drill bits. Drill bits can cut even when stationary.</li> <li>• Inspect tool before use. Replace any worn, damaged, or missing parts. A damaged or improperly assembled tool can malfunction, injuring nearby personnel.</li> <li>• Inspect hydraulic hoses and couplings every operating day. Repair or replace if leakage, cracking, wear or damage is evident. Damaged hoses or couplings can fail resulting in injury or property damage.</li> <li>• Use this tool for manufacturer’s intended purpose only. Use other than that which is described in this manual can result in injury or property damage.</li> <li>• Make sure all bystanders are clear of the work area when handling, starting and operating the tool. Nearby personnel can be injured by flying or falling debris or by flying parts in the event of a tool malfunction.</li> </ul>

<b>IMPORTANT</b>
<p>Procedure for connecting or disconnecting hydraulic hoses, fittings, or components:</p> <ol style="list-style-type: none"> <li>1. Move the flow lever on the hydraulic power source to the off position.</li> <li>2. Stop the hydraulic power source.</li> <li>3. Follow the sequence under “Hose Connections” to prevent pressure buildup. In case some pressure has built up, loosen hoses, fittings, or components slowly.</li> </ol>

<b>IMPORTANT</b>
<p>Emergency stop procedure:</p> <ol style="list-style-type: none"> <li>1. Release the trigger.</li> <li>2. Shut off the hydraulic power source.</li> </ol>

*Note: Keep all decals clean and legible, and replace when necessary.*

**Identification**

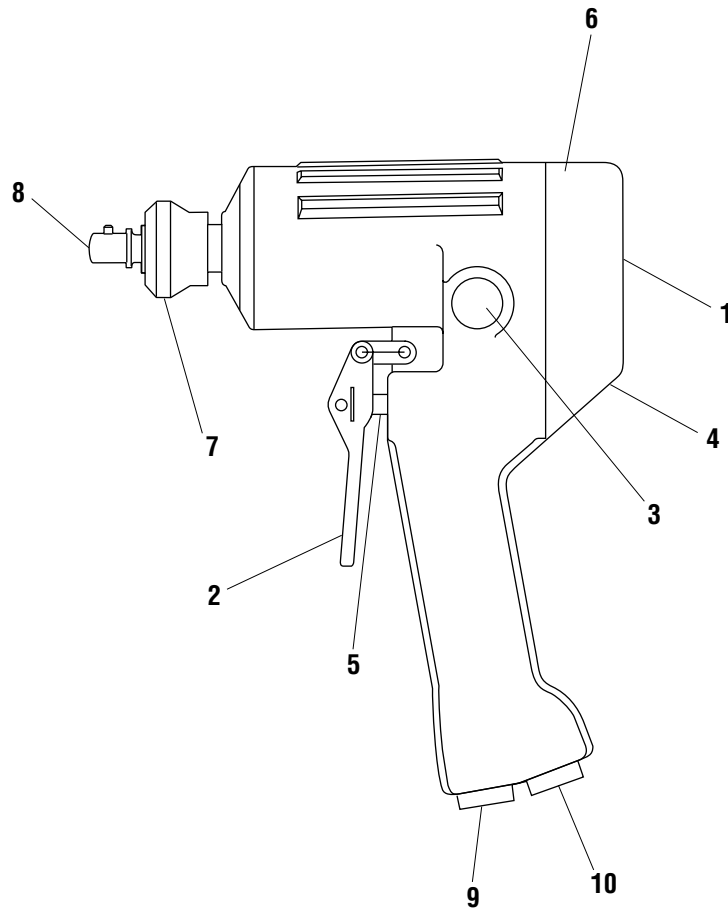

**Figure 1**  
**Model 48330 Shown**

- |   |                               |
|---|-------------------------------|
| 1. Serial Number                                    | 6. Hydraulic Gear Motor       |
| 2. Trigger  | 7. Quick-Change Chuck         |
| 3. Reversing Spool                                  | 8. Adapter, 1/2"              |
| 4. Open-Center/Closed-Center<br>Spool and Indicator | 9. Pressure (supply) Port "P" |
| 5. Trigger Spool                                    | 10. Tank (return) Port "T"    |

**Specifications**

**Impact Wrench**

Type of Hydraulic System .....	Open-center or closed-center
<b>Hydraulic Ports</b>	
Pressure .....	3/4–16 UNF SAE O-ring
Return .....	3/4–16 UNF SAE O-ring
<b>Mass/Weight</b>	
48330 .....	3.2 kg (7.1 lb)
48329 .....	3.1 kg (6.9 lb)
Length .....	208 mm (8.19")
Width .....	106 mm (4.19")
Height .....	268 mm (10.56")
RPM Range .....	4400–9700
Output Torque .....	542 Nm (400 ft-lb)
<b>Drive Size</b>	
48330 .....	7/16" hex quick-change chuck, 1/2" square drive
48329 .....	1/2" square drive

**Hydraulic Power Source**

<b>⚠ WARNING</b>
<p>Do not exceed the following hydraulic power source maximums:</p> <ul style="list-style-type: none"> <li>• Hydraulic flow: 37.9 l/min (10 gpm).</li> <li>• Pressure relief: 138 bar (2000 psi).</li> <li>• Back pressure: 13.8 bar (200 psi).</li> </ul> <p>Failure to observe this warning could result in severe injury or death.</p>

Type of Hydraulic System .....	Open-center or closed-center
<b>Flow</b>	
Minimum .....	15.1 l/min (4 gpm)
Recommended .....	18.9–30.3 l/min (5–8 gpm)
Maximum .....	37.9 l/min (10 gpm)
<b>Operating Pressure</b>	
Minimum .....	96.6 bar (1000 psi)
Maximum .....	138 bar (2000 psi)
Filtration .....	10 micron (nominal)
Pressure Relief Setting .....	138 bar (2000 psi)
Back Pressure (maximum)* .....	13.8 bar (200 psi)

\* 13.8 bar (200 psi) is the maximum agreed standard back pressure for the HTMA (Hydraulic Tool Manufacturers Association). Fairmont tools will operate satisfactorily at this standard.

**Hydraulic Power Source (cont'd)**

1. Maximum hydraulic fluid temperature must not exceed 60 °C (140 °F). A sufficient oil cooling capacity is needed to limit the hydraulic fluid temperature.
2. Hydraulic flow must not exceed 37.9 l/min (10 gpm). Install a flow meter in the return line to measure the rate of hydraulic flow before using the tool.
3. Pressure relief valve setting must not exceed 138 bar (2000 psi) at the tool's maximum flow. Locate the pressure relief valve in the supply circuit to limit excessive hydraulic pressure to the tool.

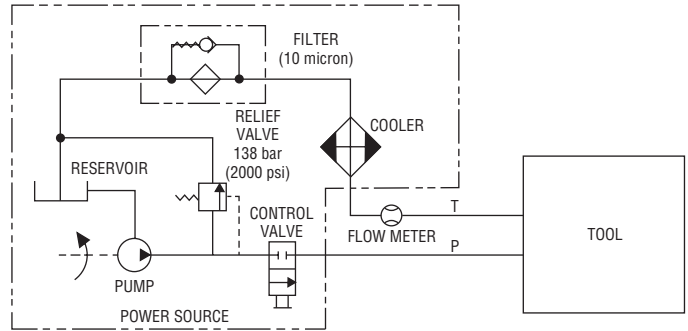

**Figure 2  
Hydraulic Schematic**

**Recommended Hydraulic Fluids**

	<b>⚠ WARNING</b>
	<p>Electric shock hazard:</p> <p>When using this unit near energized electrical lines, select and maintain the hydraulic fluid to meet the minimum dielectric standards required by your safety department.</p> <p>Failure to observe this warning could result in severe injury or death.</p>

Use any non-detergent, petroleum-based hydraulic fluid which meets the following specifications or HTMA specifications.

S.U.S. @

38 °C (100 °F) .....	140 to 225
99 °C (210 °F) .....	40 minimum
Flash Point .....	170 °C (340 °F) minimum
Pour Point .....	–34 °C (–30 °F) minimum

## Hoses and Fittings

### Installation and Maintenance

Refer to publication 999 3032.3, SAE J1273 (Hose and Hose Assemblies).

### Replacement

Refer to a Fairmont catalog or publication 999 1032.2, Low Pressure Quick Couplers, Adapters, and Hoses.

<b>⚠ WARNING</b>
Do not disconnect tool, hoses, or fittings while the power source is running or if the hydraulic fluid is hot. Hot hydraulic fluid could cause serious burns.

## Hose Connections

### Connecting Hoses

1. Move the flow lever on the hydraulic power source to the off position.
2. Stop the hydraulic power source.
3. Connect the return hose to the return port on the hydraulic power source, and then to the return port on the tool.
4. Connect the pressure hose to the pressure port on the tool, and then to the pressure port on the hydraulic power source.

### Disconnecting Hoses

1. Move the flow lever on the hydraulic power source to the off position.
2. Stop the hydraulic power source.
3. Disconnect the pressure hose from the hydraulic power source, and then from the tool.
4. Disconnect the return hose from the tool, and then from the hydraulic power source.
5. Install dust caps over the ports to prevent contamination.

Operation

Impact Bits

Fairmont recommends using Greenlee Impact Style Bits.

<p><b>⚠ WARNING</b></p> <p>Some impact bits with a long spiral or wide flute spacing may not be acceptable to use with this tool. These bits can whip or bend under sideload. Do not use bits exhibiting these characteristics with the H8508 Impact Wrench.</p> <p>Failure to observe this warning could result in severe injury or death.</p>
---

UPC No. 78-3310-	Hole Dia.		Overall Length		Hex Shank		Weight	
	inch	mm	inch	mm	inch	mm	lb	g
37868	9/16	14.3	18	457	7/16	11.1	0.9	409
37869	11/16	17.5	18	457	7/16	11.1	1.1	499
37870	13/16	20.6	18	457	7/16	11.1	1.4	636
37871	15/16	23.8	18	457	7/16	11.1	1.5	681
37872	1-1/16	27.0	18	457	7/16	11.1	1.7	772
37873	9/16	14.3	22	559	7/16	11.1	1.2	545
37874	11/16	17.5	22	559	7/16	11.1	1.5	681
37875	13/16	20.6	22	559	7/16	11.1	1.8	817
37876	15/16	23.8	22	559	7/16	11.1	2.1	953
37877	1-1/16	27.0	22	559	7/16	11.1	2.2	998

1. Inspect the drill bit to be installed. Discard the bit if cracks, chips or gouges are evident.
2. Inspect the quick-change chuck (7). Remove any dirt or other contamination that may have accumulated in the chuck (7).
3. Slide and hold quick-change chuck (7) away from tool and remove drive shank (8).
4. Insert desired bit into hex socket of tool and release chuck (7).
5. To remove drill bit, slide and hold quick-change chuck (7) away from tool and remove bit.

**1/2" Socket Drive Adapter and Sockets**  
(See Figure 1)

1. Inspect quick-change chuck (7). Remove any dirt or other contamination that may have accumulated in the chuck.
2. To insert 1/2" socket drive adapter, slide and hold quick-change chuck (7) away from tool. Insert socket drive adapter into chuck and release chuck.
3. USE SOCKETS APPROVED FOR IMPACT WRENCH USE ONLY. Inspect 1/2" drive socket to be installed. DISCARD SOCKET IF CRACKS, CHIPS OR GOUGES ARE EVIDENT. Install socket on socket drive adapter.
4. To remove socket drive adapter, remove socket from adapter. Slide and hold quick-change chuck (7) away from tool. Remove socket drive adapter.

**Setting Tool for Open-Center or Closed-Center Operation**

All H8508 models are equipped to allow the tool to be used with either an open-center or closed-center hydraulic power system.

**Closed-Center Hydraulic System**

Hold the tool as you would when operating, observe rear of trigger spool, turn center spool in trigger spool (Figure 1, Item 4) clockwise until spool stops. The tool is now ready for closed-center operation.

**Open-Center Hydraulic System**

Hold the tool as you would when operating, observe rear of trigger spool (Fig. 1, Item 4), turn center spool in trigger spool counterclockwise until spool backs out to snap-ring. The tool is now ready for open-center operation.

**Open-Center/Closed-Center Hydraulic System (for tools with serial numbers through 199)**

Turn center spool in trigger spool (Figure 1, Item 4) so spring pin indicator points upward at the letter "C". The tool is now ready for closed-center operations. Turn center spool in trigger spool so spring pin indicator points downward at the letter "O". The tool is now ready for open-center operation.



Operation (cont'd)

	<b>⚠ WARNING</b>
	<p>Electric shock hazard:</p> <p>This tool is not insulated. When using this unit near energized electrical lines, use only certified nonconductive hoses and proper personal protective equipment.</p> <p>Failure to observe this warning could result in severe injury or death.</p>

	<b>⚠ WARNING</b>
	<p>Tool and drill bit may be hot during and after operation. Contact with hot surfaces could result in serious injury.</p>

<b>⚠ WARNING</b>
<ul style="list-style-type: none"> <li>• Keep all parts of the body away from rotating parts when the tool is in operation. Contact with moving parts can result in severe injury.</li> <li>• Do not change accessories, inspect, adjust or clean tool when it is connected to a power source. Accidental start-up can result in serious injury.</li> <li>• Maintain a firm grip on tool, using both hands at all times. Serious injury can result if an operator does not control the tool.</li> <li>• Do not lock trigger in the power-ON position. Operator can not stop tool when trigger is locked.</li> </ul> <p>Failure to observe these warnings could result in severe injury or death.</p>

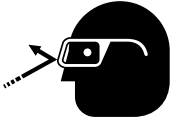
	<b>⚠ WARNING</b>
	<p>Wear eye protection when operating or servicing this tool.</p> <p>Failure to wear eye protection could result in serious eye injury from flying debris or hydraulic oil.</p>

<b>⚠ WARNING</b>
<p>Do not reverse hydraulic flow. Operation with hydraulic flow reversed can cause tool malfunction. Connect the pressure (supply) hose and tank (return) hose to the proper ports.</p> <p>Failure to observe this warning could result in severe injury or death.</p>

<b>⚠ WARNING</b>
<ul style="list-style-type: none"> <li>• Use only impact style bits. Bits not designed for impact applications can break and cause severe injury.</li> <li>• Use only sockets approved for impact use. Accessories not designed for impact applications can break and cause severe injury.</li> <li>• Inspect drill bits and sockets before use. Discard damaged bits and sockets. Damaged accessories can break and cause severe injury.</li> </ul>

<b>⚠ CAUTION</b>
<ul style="list-style-type: none"> <li>• Wear protective gloves when handling, removing and installing drill bits. Drill bits can cut even when stationary.</li> <li>• Inspect tool before use. Replace any worn, damaged, or missing parts. A damaged or improperly assembled tool can malfunction, injuring nearby personnel.</li> <li>• Inspect hydraulic hoses and couplings every operating day. Repair or replace if leakage, cracking, wear or damage is evident. Damaged hoses or couplings can fail resulting in injury or property damage.</li> <li>• Use this tool for manufacturer's intended purpose only. Use other than that which is described in this manual can result in injury or property damage.</li> <li>• Make sure all bystanders are clear of the work area when handling, starting and operating the tool. Nearby personnel can be injured by flying or falling debris or by flying parts in the event of a tool malfunction.</li> </ul>

**Operation (cont'd)****Setup** (See Figure 1)

1. Stop the power source. Disconnect tool from power source.
2. Set open-center/closed-center spool (4) to correspond to the power source hydraulic system, that the tool will be connected to. See Operation—Setting Tool for Open-Center/Closed-Center Operation.
3. Slide desired 1/2" square drive socket onto 1/2" drive on tool (8) or insert desired bit in quick-change chuck.
4. Connect the hydraulic hoses from the power source to the tool. Start the power source.
5. It is recommended that the power source be allowed to run (idle) for a few minutes to warm the hydraulic reservoir fluid. Actuating the tool intermittently will reduce the time required to warm the fluid to an efficient operating temperature.

**Operation** (See Figure 1)

1. Set reversing spool (3) to desired position (forward or reverse).  
*Note: Never shift the reversing spool (3) while the tool is operating. Always allow the tool to come to a complete stop before changing drill direction. Shifting the spool while the tool is operating may cause internal tool damage.*
2. Grasp the trigger handle. Place your opposite hand on the top of the tool. This will allow leverage to be applied while operating.
3. To start the wrench, squeeze the trigger (2).
4. To stop the wrench, release the trigger (2).
5. After the tool has stopped rotating, lay the wrench on a flat surface.
6. When the tool is not in use, stop the power source to reduce heat and wear on the tool components.

## Maintenance

### ⚠ CAUTION

- Inspect tool before use. Replace any worn, damaged, or missing parts. A damaged or improperly assembled tool can malfunction, injuring nearby personnel.
- Inspect hydraulic hoses and couplings every operating day. Repair or replace if leakage, cracking, wear or damage is evident. Damaged hoses or couplings can fail resulting in injury or property damage.

Use this maintenance schedule to maximize the tool's service life.

*Notes: Keep all decals clean and legible, and replace when necessary.*

*When disposing of any components (hydraulic hoses, hydraulic fluid, worn parts, etc.), do so in accordance with federal, state, and local laws or ordinances.*

#### Daily

1. Wipe all tool surfaces clean.
2. Inspect the hydraulic hoses and fittings for signs of leaks, cracks, wear, or damage. Replace if necessary.
3. Install dust caps over the hydraulic ports when the tool is disconnected.

#### Monthly

Perform a thorough inspection of the hydraulic hoses and fittings as described in publication 999 3032.3, SAE J1273 (Hose and Hose Assemblies).

#### Quarterly

Remove the hammer case cap, anvil, impact mechanism assembly, spacer, washers and thrust bearing. Clean the grease from the inside of the handle cavity and all impact components. Apply a coat of grease (Mobile Grease HP) to thrust washers (48319), thrust bearing (48318), hammers (48345), hammer pins (48346) and anvil (48347) or (48397). Pack the hammer frame center space before pushing the anvil into the grease pocket. Reassemble components and tighten hammer case cap (48516) securely. If wrench is used under severe operating conditions or hard-duty cycle, mechanism may need to be greased more often.

#### Semi-Annually

Drain the hydraulic system fluid. Flush out the hydraulic system and fill with new, clean fluid. However, if the fluid turns dark or becomes milky colored, it should be changed as soon as possible.

## Troubleshooting

### Before You Begin

1. Tool must be connected to the correct power source system. See Tool Specification for type of hydraulic system required. Verify the power source hydraulic system.
2. Verify that the pressure and return hoses are connected properly to the tool and power source ports.
3. Power source reservoir must be filled to FULL level with hydraulic fluid.
4. Start the power source. All power source shut-off devices must be engaged or opened (clutch engaged, separate on/off valves open, etc.).
5. After verifying all of the above, check the tool to see if it operates.

If the tool does not operate, it will be necessary to pinpoint the tool, hoses or power source as the problem area. The following steps will help to determine the problem area.

### Determining the Problem Area

1. Stop the power source. Disconnect the existing tool from the hoses and power source.
2. Connect a known, properly operating tool to the hoses and power source. See the tool's operator's manual for correct hook-up procedure. Start the power source.

If the known, properly operating tool operates, the problem is in the disconnected tool. See the troubleshooting charts in this operator's manual.

If the known, properly operating tool does not operate, the problem is likely to be in the hoses or the power source. Proceed to Step 3.

3. Stop the power source. Disconnect the existing hoses from the known, properly operating tool and power source.
4. Connect a different set of hoses to the known, properly operating tool and power source. Start the power source.

If the known, properly operating tool operates with the different set of hoses, the problem is in the disconnected hoses.

If the known, properly operating tool does not operate, the problem is in the power source. See your power source operator's manual for troubleshooting.

**Troubleshooting (cont'd)**

PROBLEM	PROBABLE CAUSE	POSSIBLE REMEDY
<p>Tool inoperative.</p>	<p>Tool connected to improper power source hydraulic system.</p> <p>No hydraulic fluid in system or fluid level low.</p> <p>Incorrect hydraulic fluid viscosity.</p> <p>Tool components loose.</p> <p>Dirt, contaminants, etc., in tool components.</p> <p>Tool components worn or damaged.</p> <p>Hose connections to power source reversed.</p>	<p>See Tool Specifications for type of hydraulic system required. Verify power source hydraulic system.</p> <p>Check fluid level. Fill to FULL mark. Check system for leaks.</p> <p>Use fluid viscosity recommended. See Recommended Hydraulic Fluids.</p> <p>Tighten component hardware.</p> <p>Disassemble tool and clean components.</p> <p>Disassemble tool. Replace worn or damaged components.</p> <p>Depressurize hydraulic system. Reverse hose connections.</p>
<p>Tool operates erratically.</p>	<p>Hydraulic fluid cold.</p> <p>Air in system.</p> <p>Tool components sticking or binding.</p> <p>Dirt, contaminants, etc., in tool components.</p>	<p>Viscosity of fluid may be too high at start of tool operation. Allow fluid to warm to operating temperature. Actuating tool intermittently will reduce time required to warm fluid to an efficient operating temperature.</p> <p>Check pump suction line for damage or loose clamps. Tighten clamps or replace components, if necessary. Fill reservoir.</p> <p>Check for dirt or gummy deposits. Clean components. Check for worn or damaged components. Replace components.</p> <p>Disassemble tool and clean components.</p>

**Troubleshooting (cont'd)**

PROBLEM	PROBABLE CAUSE	POSSIBLE REMEDY
<p>Tool impacts slowly.</p>	<p>Power source components not adjusted correctly.</p> <p>Hydraulic fluid cold.</p> <p>Hydraulic fluid level low.</p> <p>Hydraulic fluid viscosity too heavy.</p> <p>Tool components loose.</p> <p>Dirt, contaminants, etc., in tool components.</p> <p>Tool components worn or damaged.</p> <p>Damaged hose couplings.</p>	<p>Refer to power source operator's manual for recommended speed, flow, and pressure settings.</p> <p>Viscosity of fluid may be too high at start of tool operation. Allow fluid to warm to operating temperature. Actuating tool intermittently will reduce time required to warm fluid to an efficient operating temperature.</p> <p>Check fluid level. Fill to FULL mark. Check system for leaks.</p> <p>Use fluid viscosity recommended. See Recommended Hydraulic Fluids.</p> <p>Tighten component hardware.</p> <p>Disassemble tool. Clean components.</p> <p>Disassemble tool. Replace worn or damaged components.</p> <p>Inspect couplings. Replace if damaged.</p>
<p>Tool operates too fast.</p>	<p>Power source components not adjusted correctly.</p> <p>Tool components sticking or binding.</p>	<p>Refer to power source operator's manual for recommended speed, flow, and pressure settings.</p> <p>Check for dirt or gummy deposits. Clean components. Check for worn or damaged components. Replace components.</p>

**Troubleshooting (cont'd)**

PROBLEM	PROBABLE CAUSE	POSSIBLE REMEDY
Tool feels hot.	<p>Hydraulic fluid level low.</p> <p>Hydraulic fluid viscosity too light.</p> <p>Hydraulic fluid dirty.</p> <p>Tool control valve stuck in partial power-ON position.</p> <p>Power source components not adjusted correctly.</p> <p>Dirt, contaminants, etc., in tool components.</p> <p>Worn or damaged O-rings or gaskets.</p> <p>Tool components worn or damaged.</p>	<p>Check fluid level. Fill to FULL mark. Check system for leaks.</p> <p>Use fluid viscosity recommended. See Recommended Hydraulic Fluids.</p> <p>Drain reservoir, flush and fill with clean fluid. Change filter.</p> <p>Free valve so it returns to neutral position.</p> <p>Refer to power source operator's manual for recommended speed, flow, and pressure settings.</p> <p>Disassemble tool. Clean components.</p> <p>Replace worn or damaged O-rings or gaskets.</p> <p>Disassemble tool. Replace worn or damaged components.</p>

**Troubleshooting (cont'd)**

PROBLEM	PROBABLE CAUSE	POSSIBLE REMEDY
Tool leaks hydraulic fluid.	<p>Tool components loose.</p> <p>Worn or damaged O-rings or gaskets.</p> <p>Tool components worn or damaged.</p>	<p>Tighten component hardware.</p> <p>Replace worn or damaged O-rings or gaskets.</p> <p>Disassemble tool. Replace worn or damaged components.</p>
Tool trigger plunger sticks or works hard.	<p>Check for dirt or gummy deposits.</p> <p>Trigger binding (trigger bent, trigger pivot pin too tight, etc.).</p>	<p>Clean components.</p> <p>Inspect, adjust trigger where binding occurs.</p>
Power source works, but tool lacks power or does not operate.	<p>Inappropriate hydraulic system.</p>	<p>Check type of hydraulic power source. open-center or closed-center.</p>
Power source works, but tool lacks power and/or impacts slowly.	<p>Relief valve setting in tool not correct.</p>	<p>Return tool to factory for service.</p>
Tool appears to operate normally but lacks impact power or does not drill.	<p>Impact mechanism dry. Grease has been thrown off.</p> <p>Incorrect grease or overpacked.</p>	<p>Regrease impact mechanism. See the Maintenance Schedule section of this manual.</p> <p>Regrease impact mechanism. See the Maintenance Schedule section of this manual.</p>
Grease leaks at anvil bushing, wrench warm.	<p>Heavy duty cycle, heat caused grease to liquify.</p>	<p>Normal, mechanism may require grease more often, see the Maintenance Schedule section of this manual.</p>



## Disassembly

Complete disassembly of the tool is not recommended. Return the tool to your nearest authorized Fairmont distributor or to the factory.

	<h3>⚠ WARNING</h3>
	<p><b>Skin injection hazard:</b> Oil under pressure easily punctures skin, causing serious injury, gangrene, or death. If you are injured by escaping oil, seek medical attention immediately.</p> <ul style="list-style-type: none"> <li>• Do not use hands to check for leaks.</li> <li>• Do not hold hose or couplers while the hydraulic system is pressurized.</li> <li>• Depressurize the hydraulic system before servicing.</li> </ul>

<h3>⚠ WARNING</h3>
<p>Do not disconnect tool, hoses, or fittings while the power source is running or if the hydraulic fluid is hot. Hot hydraulic fluid could cause serious burns.</p>

<h3>IMPORTANT</h3>
<p>Procedure for connecting or disconnecting hydraulic hoses, fittings, or components:</p> <ol style="list-style-type: none"> <li>1. Move the flow lever on the hydraulic power source to the off position.</li> <li>2. Stop the hydraulic power source.</li> <li>3. Follow the sequence under “Hose Connections” to prevent pressure buildup. In case some pressure has built up, loosen hoses, fittings, or components slowly.</li> </ol>

The disassembly procedure is divided into sections of the tool. Complete disassembly of the tool is seldom necessary. Disassemble only the areas necessary to correct the problem. See Exploded View and Parts List for identification of parts as they are removed.

Disassembly should be done on a flat, clean surface. Some parts may fall free during disassembly. To prevent part loss or damage, keep the tool as close to the working surface as possible.

Inspect all parts as they are disassembled and mating parts in the tool that are not removed for signs of damage, wear, cracks, etc. Replace any parts which appear to be damaged.

When disassembling tool for service it is recommended that O-rings, back-up rings and gaskets be replaced.

### Quick-Change Chuck (See Figure 7)

1. Remove adapter (61) from retaining sleeve (50).
2. Press on thrust ring (52) to expose thrust ring lock (51). Remove thrust ring lock (51) thrust ring (52) and spring (53). Slide retaining sleeve (50) off anvil (49) and remove the two steel balls (54).
3. Remove the second thrust ring lock (51) if anvil (49) needs to be removed from hammer case cap (55).

*Note: To prevent the loss of any steel balls, it is recommended to perform this step over a clean, empty container to catch any components that may fall free.*

*Note: If either thrust ring (51) becomes sprung or out-of-round during disassembly, discard and replace with a new ring.*

### Hammer Case Components

1. Using flats provided on hammer case cap (55) unscrew cap and remove from tool.  
The remaining impact mechanism parts can now be removed from tool (items 46, 47 and 48).
2. Remove spacer (45), thrust bearing (43) and thrust washers (44) from hammer case cavity.

### Motor (See Figures 6, 7, and 9)

1. Remove socket head cap screws (16) and pull motor cap (6) from handle (1). Remove gasket (15). If necessary, remove dowel pins (14).
2. Pull idler shaft (13) with gear (10) from handle. Remove gear (10) from idler shaft (13). If necessary, remove drive pin (12) and retaining clip (11) from idler shaft (13).
3. Remove retaining clip (11) gear (10) and Woodruff key (9) from drive shaft (8). Push drive shaft (8) toward hammer case cavity and remove from handle (1).

### Bearing Replacement

*Note: If bearings in motor cap (6) or bearings in handle (1) are damaged or worn, Fairmont recommends replacing the component as an assembly with the bearings already pressed in or return it to Fairmont for repair.*

## Disassembly (cont'd)

### Trigger and Control Spool—48696

(See Figures 7 and 8)

### 48273 (48330/48329 prior to S/N 300)

(See Figures 4 and 7)

1. Remove spring pin (42) from trigger spool (29) by pressing or tapping with a hammer and punch.  
*Note: Support trigger (41) so pressing or tapping does not bend trigger spool (29).*
2. Remove washer (39), spring (38), snap ring (37), and washer (36). Trigger spool (29) may now be pushed out of handle (1). Push spool toward trigger side of tool.
3. Remove snap ring (33). open-center/closed-center spool (31) may now be removed to service O-ring (34). (O-ring [30] prior to S/N 300)
4. Ball (32) is loose in this assembly. Take caution to catch ball when it falls free. (No ball [32] prior to S/N 300)

### Reversing Spool

1. Remove reversing spool (19) by loosening and removing cap (24) on left side of tool and pulling spool (19) out right side of tool.  
*Note: For tool orientation (left and right) grip tool as you would use it and view tool looking at motor cap (6). See Figure 6.*  
*Note: Attempting to push the reversing spool (19) the opposite way through the bore will cause damage to O-rings (25 and 26) and could allow particles of O-ring to get into motor.*
2. Remove plug (22), spring (21) and poppet (20).
3. Repeat procedure for right side of reversing spool (19).  
*Note: If set screws (23 and 60) have not been disturbed and internal components are returned to the same side of spool (19), the relief valve setting may not have been affected and tool will perform properly when assembled.*  
*Note: Relief valve setting may require checking when tool is reassembled.*

## Assembly

### Inspection

1. Motor Cap (6) and Handle (1). Mating surfaces, gear cavities, oil passageways, etc.; must be smooth and free of grooves or nicks. If either component has grooves or nicks, replace the component as an assembly with the bearings already pressed in.
2. Drive Shaft (8), Idler Shaft (13) and Gears (10). All surfaces, including gear teeth, must be smooth and free of grooves or nicks. If any component is damaged, replace the component.
3. Bearing (3 and 7). Hold motor cap or handle assembly in one hand or place on a flat surface. Insert drive shaft (8) or idler shaft (13) into bearing. Spin the shaft. The shaft should turn smoothly. If any roughness is noted, Fairmont recommends replacing the component as an assembly with the bearings already pressed in.
4. Bearing (56) in hammer case cap (55). Slide anvil (49) into bearing (56). Turn anvil (49). The anvil should turn smoothly. If any roughness is noted, check anvil surface. If problem is the bearing surface, replace hammer case cap assembly as an assembly with the bearing already pressed in.
5. Thrust bearing (43) and thrust washers (44). Turn bearing on washer surfaces. Bearing should roll smoothly. If any roughness is felt, replace the components.
6. Trigger Spool (29). All surfaces must be free of grooves or nicks. If the component has grooves or nicks, replace the component.
7. Reversing Spool (19). All surfaces must be free of grooves or nicks. If the component has grooves or nicks, replace the component.
8. Hammer Frame (46), Anvil (49), Hammers (47) and Pins (48). All surfaces must be free of grooves, nicks, or cracks. If any component has grooves, nicks, or cracks, replace the component.
9. O-rings. Always replace O-rings in components that have been disassembled with new O-rings during assembly. A packing kit is available that includes all O-rings and gaskets.
10. Gasket (15). Always replace gaskets when motor cap or hammer case is removed from handle assembly. Install new gasket (15).

## Assembly (cont'd)

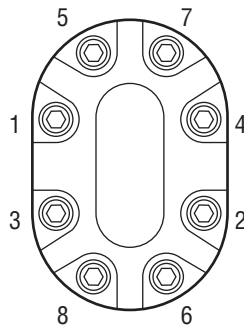

**Figure 3**  
**Torque Sequence**

When assembling parts, refer to the Illustrations and Parts Lists for correct orientation and placement of parts.

Clean grease and oil from all parts (take care to protect eyes), then dry thoroughly. Do not expose O-rings or other packing components to cleaning agent for long periods of time.

Inspect all parts as they are assembled for signs of damage, wear, cracks, etc. Do not install any parts which appear to be damaged.

Apply hydraulic fluid or O-ring lubricant to all O-rings and all metal surfaces which O-rings must slide over. When installing an O-ring over a sharp edge, use a rolling action to avoid damage to O-ring.

Wherever assembled parts cause metal-to-metal contact, coat the surfaces with hydraulic fluid or O-ring lubricant.

### Motor (See Figures 6, 7 and 9)

1. Install new O-ring (4) and back-up ring (5) into drive shaft opening of handle (1) using an O-ring tool. Be careful, do not damage O-ring during installation.
2. Lubricate drive shaft (8) and slide into opening in handle (1) through the O-rings and back-up ring from impact mechanism side of tool.
3. Install Woodruff key (9) and one gear (10) onto drive shaft (8), guiding keyway in gear (10) over Woodruff key (9). Fasten gear to drive shaft with retaining clip (11).
4. Install drive pin (12) into idler shaft (13), if removed. Slide remaining gear (10) onto idler shaft (13), guiding keyway in gear (10) over drive pin (12). Install idler shaft and gear into handle (1), meshing the two gears (10) together. Use retaining clip (11) to restrain lateral movement of idler shaft.
5. Install dowel pins (14) into handle (1) if removed. Install new gasket (15).
6. Install motor cap (6) onto handle (1).
7. Secure motor cap (6) to handle (1) with cap screws (16). Torque cap screws (16) to 80 inch-pounds. Follow torque sequence shown in Figure 3.

### Reversing Spool (See Figure 5)

1. Install O-ring (25) onto reversing spool (19). Replace O-ring (26) in handle (1).
2. Install O-ring (30) on plug (22). At O-ring end of spool (19) install poppet (20), spring (21) and plug (22). Secure assembly with cap (24).
3. Slide reversing spool assembly into handle (1), as shown in Figure 5.
4. Install poppet (20), spring (21) and plug (22) into opposite end of spool (19). Secure with cap (24). Use two wrenches on cap (24) and tighten to 23 foot-pounds.

### Trigger, Trigger Spool, and Open-Center/Closed-Center Spool (See Figures 7 and 8)

#### 48330/48329 prior to S/N 300 (See Figures 4 and 7)

1. Install O-ring (34) (O-ring (30) prior to S/N 300) on open-center/closed-center spool (31). Install ball (32) in trigger spool (29) cavity. (No ball (32) prior to S/N 300.) Install open-center/closed-center spool (31) into trigger spool (29). Secure with snap-ring (33).
2. Install O-ring (35) onto trigger spool assembly. Replace O-ring (27) and back-up ring (28) in handle (1).
3. Slide trigger spool assembly as shown in Figure 4 or 8 into handle (1) from trigger side of tool.

#### 48330/48329 prior to S/N 300 (See Figures 4 and 7)

*Note: Slots in trigger spool (29) must be facing handle end of tool.*

1. Slide washer (36) onto trigger spool (29) and secure with snap-ring (37).
2. Slide spring (38) and washer (39) onto trigger spool (29).
3. Secure trigger (41) to trigger spool (29) with spring pin (42).
4. Secure link (40) to handle (1) and trigger (41) with spring pins (42).

*Note: Support trigger (41) so pressing or tapping on spring pins (42) does not bend trigger spool (29).*

## Assembly (cont'd)

### Hammer Case Components

*Note: Grease required for assembly of impact mechanism = Mobil Grease HP.*

1. Apply grease to thrust bearing (43) and work into needle rollers. Apply light film of grease to thrust washers (44), stack thrust washers and thrust bearing properly and place over drive shaft (8).
2. Place spacer (45) over drive shaft (8) with flange part of spacer up.

### Impact Mechanism

1. Before assembly, grease surfaces of hammer frame (46), hammers (47) hammer pin (48) and anvil (49).
2. Install the two hammers (47) 180° from each other, into hammer frame (46). Install pins (48) into hammer frame and through the hammers, then slide assembly onto spline of drive shaft (8).
3. Pack hammer frame (46) center space with grease. Install anvil (49) into hammer frame (46) and through hammers (47).
4. Install O-ring (62) over threads on hammer case cap (55).
5. Slide hammer case cap assembly (55 and 56) over anvil (49) and using flats on cap (55) screw into handle (1), tighten securely.

*Note: Apply lubrication to threads.*

### Quick-Change Chuck

1. Slide thrust ring lock (51) over anvil (49) to groove closest to hammer case cap (55).
2. Insert two balls (54) into holes in anvil (49). Slide retaining sleeve (50) onto anvil (49) "Open" side up. Insert spring (53) and thrust ring (52) into retaining sleeve (50). Depress thrust ring (52) and install thrust ring lock (51) on anvil (49). This will secure retaining sleeve (50) to anvil (49). Insert drive shank (61) into chuck.

*Note: If either thrust ring (51) becomes sprung or out-of-round during disassembly, discard and replace with a new ring.*

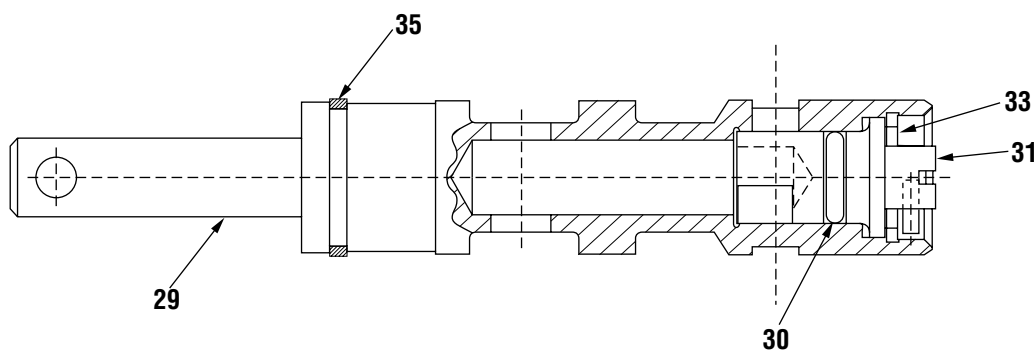

**Figure 4**  
**Spool shown in Closed-Center Position**

**Models 48330/48329**  
**(effective through serial number 299)**

Illustration

Models 48330/48329  
(effective through serial number 299)

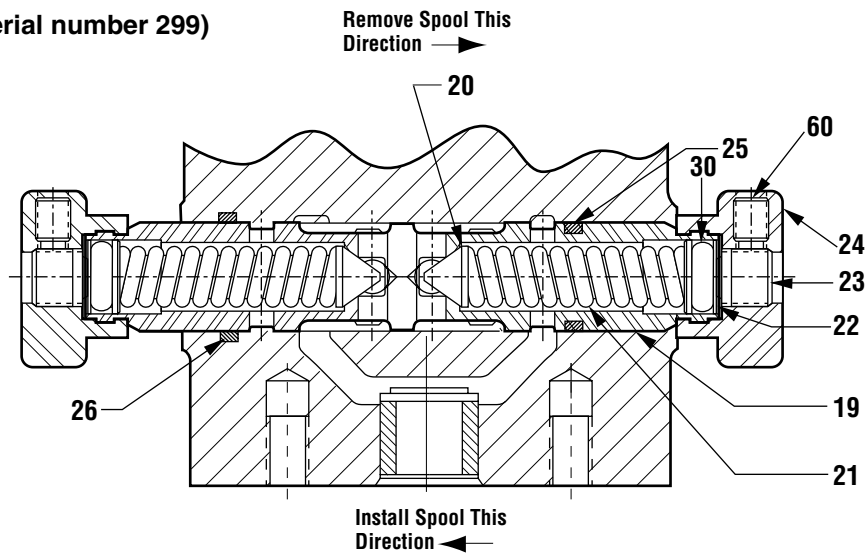

Figure 5

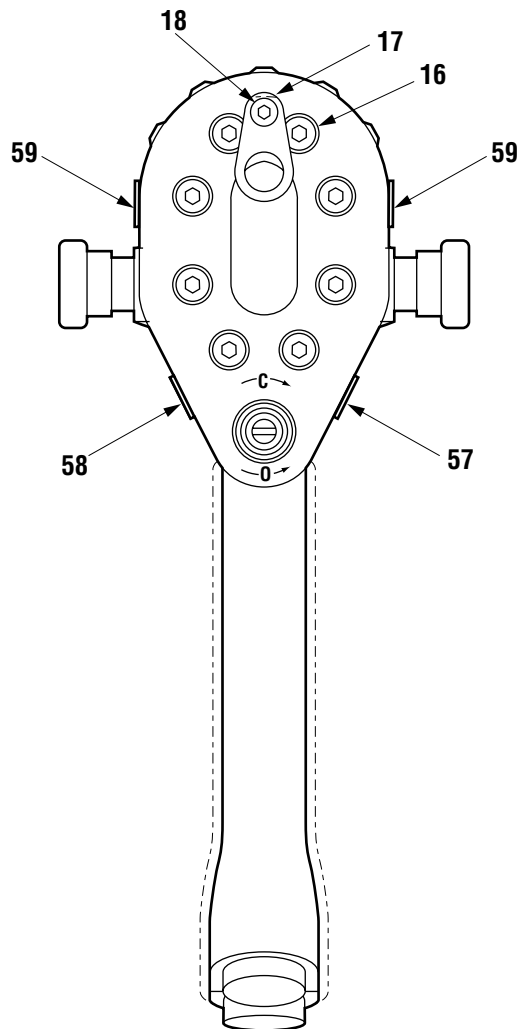

Figure 6

Illustration (cont'd)

Models 48330/48329 (effective through serial number 299)

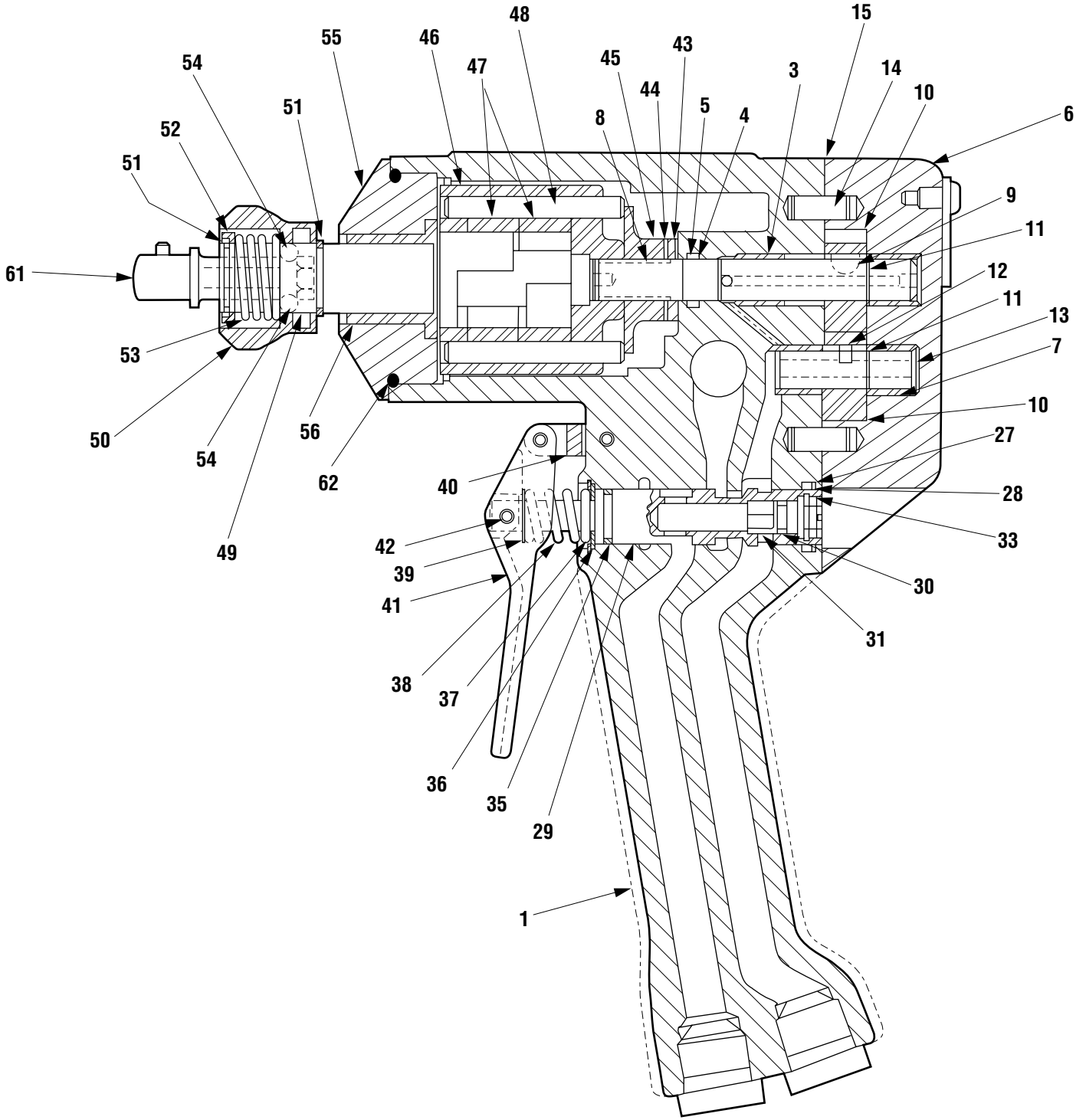

Figure 7

**Parts List**

**Models 48330/48329 (effective through serial number 299)**

Key	UPC No.	Part No.	Description	Qty.
1		48309	HANDLE ASSEMBLY .....	1
			Handle, Insulated .....	1
			Expander Plug .....	1
3	41591	F016728	Bearing .....	2
4	48707	48706	O-Ring .....	1
5		48306	Back-up Ring .....	1
6		48356	MOTOR CAP .....	1
7	41591	F016728	Bearing .....	2
8		48279	Drive Shaft .....	1
9	41592	F016729	Key .....	1
10	41630	F017105	11-Tooth Gear .....	2
11	41621	F017010	Snap Ring .....	2
12	41593	F016730	Drive Pin .....	1
13	40168	104110K	Idler Shaft .....	1
14	41624	F017014	Dowel Pin .....	2
15*		48363	Gasket .....	1
16	41889	F021674	Socket Hd Cap Screw .....	8
17		48328	Eye .....	1
18	43701	F021676	Socket Hd Cap Screw .....	1
		48382	REVERSING SPOOL ASSEMBLY .....	1
19		48361	Reversing Spool .....	1
20		48515	Poppet .....	2
21		48543	Spring .....	2
22		48621	Plug .....	2
23		905 0765.7	Set Screw .....	2
24		48380	Cap .....	2
60		48622	Set Screw .....	2
25*	41491	F015261	O-Ring .....	1
26*	41426	F013565	O-Ring .....	1
27*	48539	F011743	O-Ring .....	1
28*	43312	F021451	Back-up Ring .....	1
		48273	TRIGGER, SPOOL ASSEMBLY .....	1
29		48272	Spool-Trigger .....	1
30*	41384	F011060	O-Ring .....	3
31		48275	OC/CC SPOOL ASSEMBLY .....	1
			OC/CC Spool .....	1
			Spring Pin .....	1
33	48540	F021711	Snap Ring .....	1
35*	41491	F015261	O-Ring .....	1
36		48310	Washer .....	1
37	41648	F017595	Snap Ring .....	1
38		48311	Spring .....	1
39		48312	Washer .....	1

**Parts List (cont'd)**

**Models 48330/48329 (effective through serial number 299)**

Key	UPC No.	Part No.	Description	Qty.
40		48313	Link.....	1
41		48360	Trigger.....	1
42	48542	F015810	Spring Pin.....	3
43		48318	Thrust Bearing.....	1
44		48319	Thrust Washer.....	2
45		48364	Spacer.....	1
		48516	HAMMER CASE CAP ASSEMBLY	
55		48320	Hammer Case Cap.....	1
56		48517	Bearing.....	1
57	43550	158055	Decal—Safety.....	1
58		48512	Decal—Pressure/Flow.....	1
59		48513	Decal—ID.....	2
62*	41803	F020780	O-Ring.....	1

**For Model 48330 Only**

		48343	IMPACT MECHANISM	
46		48344	Hammer Frame.....	1
47		48345	Hammer.....	2
48		48346	Hammer Pin.....	2
49		48347	Anvil—Quick Change.....	1
50		48348	Retaining Sleeve.....	1
51		48349	Thrust Ring Lock.....	2
52		48350	Thrust Ring.....	1
53		48351	Sleeve Spring.....	1
54		48352	Ball.....	2
61	41515	F015321	Adapter.....	1

**For Model 48329 Only**

		48398	IMPACT MECHANISM	
46		48344	Hammer Frame.....	1
47		48345	Hammer.....	2
48		48346	Hammer Pin.....	2
49		48397	Anvil—1/2" Sq. Drive.....	1

**Kit**

*		48538	Seal Kit	
---	--	-------	----------	--



Illustration

Models 48330/48329 (effective with serial number 300)

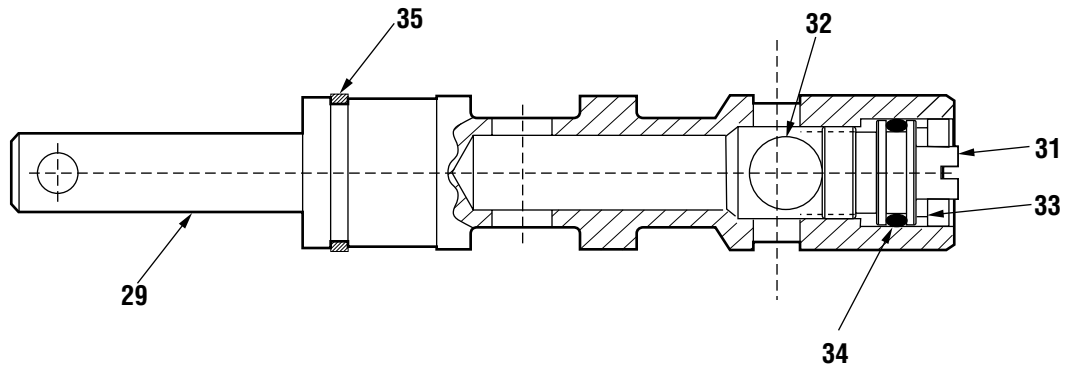

Figure 8  
Spool shown in Open-Center Position

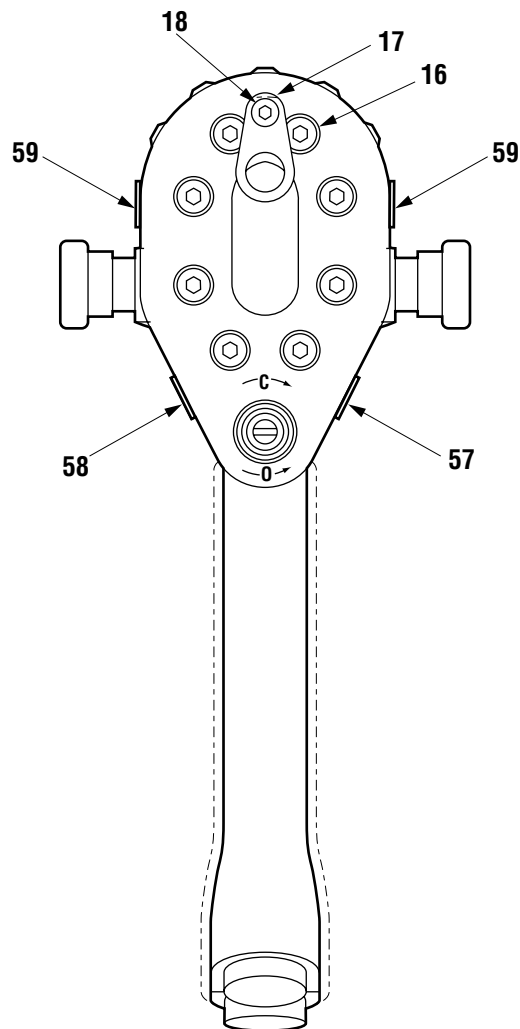

Figure 9

Illustration (cont'd)

Models 48330/48329 (effective with serial number 300)

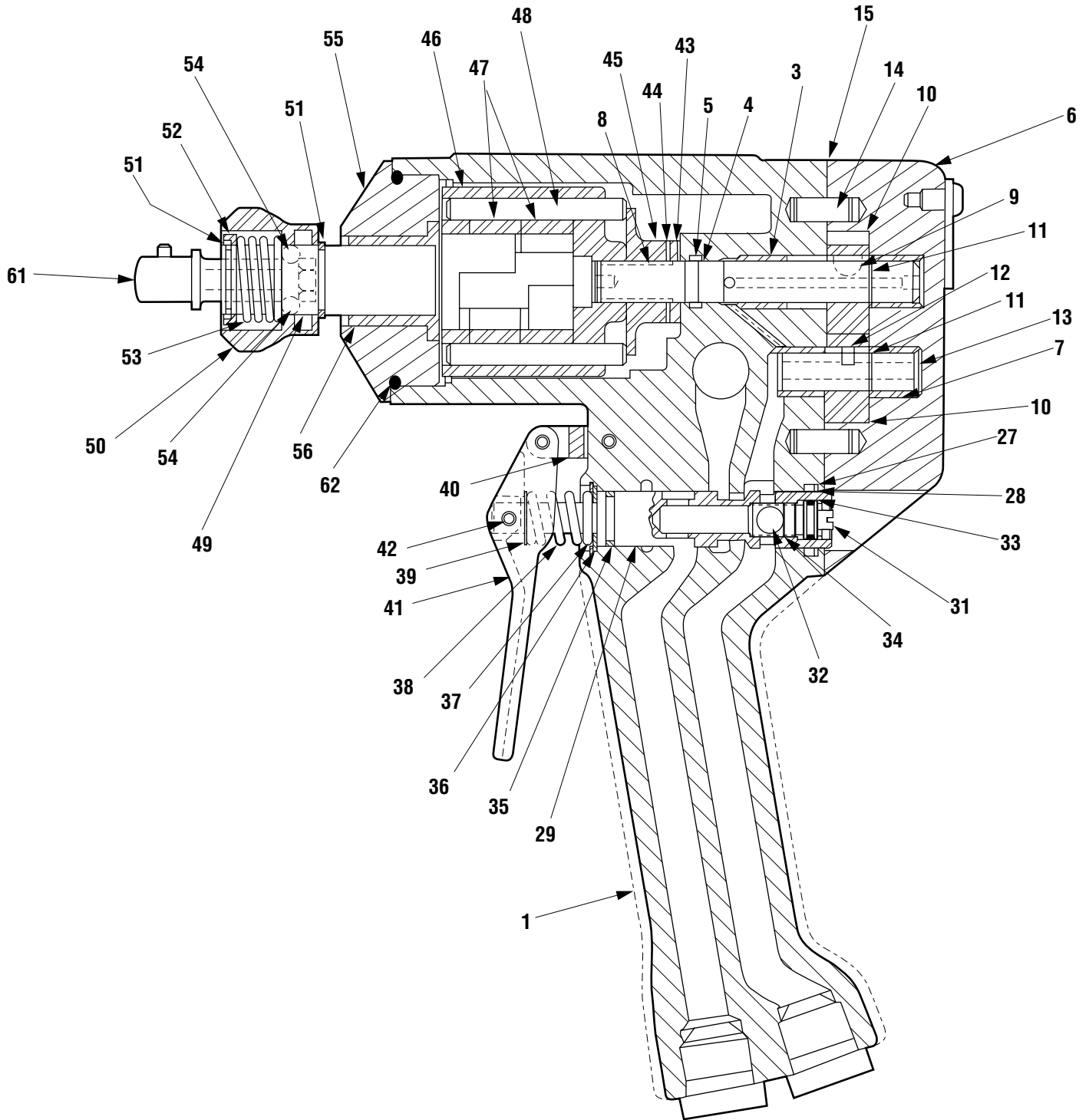

Figure 10

**Parts List**

**Models 48330/48329 (effective with serial number 300)**

Key	UPC No.	Part No.	Description	Qty.
1		48309	HANDLE ASSEMBLY .....	1
	41591	F016728	Bearing .....	2
4		48706	O-Ring .....	1
5		48306	Back-up Ring .....	1
6		48307	MOTOR CAP .....	1
7	41591	F016728	Bearing .....	2
8		48279	Drive Shaft .....	1
9	41592	F016729	Key .....	1
10	41630	F017105	11-Tooth Gear .....	2
11	41621	F017010	Snap Ring .....	2
12	41593	F016730	Drive Pin .....	1
13	40168	104110K	Idler Shaft .....	1
14	41624	F017014	Dowel Pin .....	2
15*		48363	Gasket .....	1
16	41889	F021674	Socket Hd Cap Screw .....	8
17		48328	Eye .....	1
18	43701	F021676	Socket Hd Cap Screw .....	1
		48382	REVERSING SPOOL ASSEMBLY .....	1
19		48361	Reversing Spool .....	1
20		48515	Poppet .....	2
21		48543	Spring .....	2
22		48621	Plug .....	2
23		905 0765.7	Set Screw .....	2
24		48380	Cap .....	2
60		48622	Set Screw .....	2
25*	42050	F023449	O-Ring .....	1
26*		48889	O-Ring .....	1
27*	48539	F011743	O-Ring .....	1
28*	43312	F021451	Back-up Ring .....	1
29		48696	Spool-Trigger .....	1
30*	42047	F023379	O-Ring .....	2
31		48697	OC/CC Spool .....	1
32	43829	F021411	Ball .....	1
33	48540	F021711	Snap Ring .....	1
34*	41331	F010777	O-Ring .....	1
35*	41491	F015261	O-Ring .....	1
36		48310	Washer .....	1
37	41648	F017595	Snap Ring .....	1
38		48311	Spring .....	1
39		48312	Washer .....	1
40		48313	Link .....	1
41		48360	Trigger .....	1
42	48542	F015810	Spring Pin .....	3
43		48318	Thrust Bearing .....	1

**Parts List (cont'd)**

**Models 48330/48329 (effective with serial number 300)**

Key	UPC No.	Part No.	Description	Qty.
44		48319	Thrust Washer .....	2
45		48364	Spacer .....	1
		48516	HAMMER CASE CAP ASSEMBLY	
55		48320	Hammer Case Cap .....	1
56		48517	Bearing .....	1
57	43550	158055	Decal—Safety .....	1
58		48512	Decal—Pressure/Flow .....	1
59		48513	Decal—ID .....	2
62*	41803	F020780	O-Ring .....	1

**For Model 48330 Only**

		48343	IMPACT MECHANISM	
46		48344	Hammer Frame .....	1
47		48345	Hammer .....	2
48		48346	Hammer Pin .....	2
49		48347	Anvil—Quick-Change .....	1
50		48348	Retaining Sleeve .....	1
51		48349	Thrust Ring Lock .....	2
52		48350	Thrust Ring .....	1
53		48351	Sleeve Spring .....	1
54		48352	Ball .....	2
61	41515	F015321	Adapter .....	1

**For Model 48329 Only**

		48398	IMPACT MECHANISM	
46		48344	Hammer Frame .....	1
47		48345	Hammer .....	2
48		48346	Hammer Pin .....	2
49		48397	Anvil—1/2" Sq. Drive .....	1

**Kit**

*		48538	Seal Kit	
---	--	-------	----------	--

**Accessories**

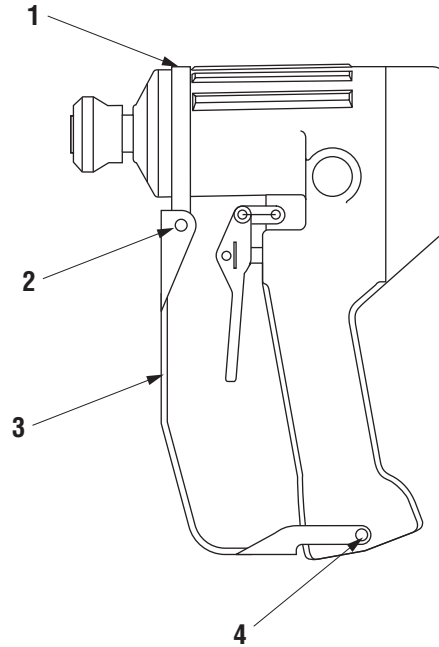
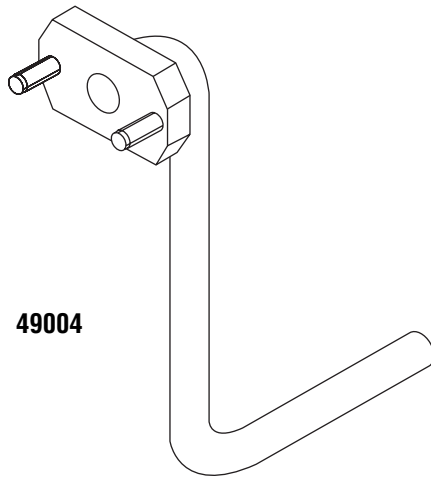

Key	UPC No.	Part No.	Description	Qty.
<b>Optional Accessories</b>				
		49004	Kit—Relief Pressure Check .....	1
<b>Trigger Guard 48518</b>				
		48518	TRIGGER GUARD GROUP .....	1
1		48399	Bracket .....	1
2	43701	F021676	#10-32 x 3/8" Socket Button Head Cap Screw .....	2
3		48327	Trigger Guard .....	1
4	41875	F021610	#10-32 x 1/2" Button Head Hex Cap Screw .....	2
<b>1/2" Square Drive Impact Socket Set (not shown)</b>				
	41769	F020028	1/2" SQUARE DRIVE IMPACT SOCKET SET .....	1
	41535	F015424	Impact Socket, 5/8 .....	1
	41536	F015426	Impact Socket, 3/4 .....	1
	41537	F015427	Impact Socket, 13/16 .....	1
	41538	F015428	Impact Socket, 7/8 .....	1
	41539	F015430	Impact Socket, 1 .....	1
	41540	F015431	Impact Socket, 1-1/16 .....	1
	41515	F015321	Adapter, Adapts Quick-Change Chuck to 1/2" Square Drive .....	1
<b>1/2" Square Socket x 5/8" Hex Socket Adapter (not shown)</b>				
	41515	F020538	Adapter, 1/2 Square Socket x 5/8 Hex Socket. ....	1



**GREENLEE®**

A Textron Company

USA	800-435-0786	Fax: 800-451-2632
	815-397-7070	Fax: 815-397-1865
Canada	800-435-0786	Fax: 800-524-2853
International	+1-815-397-7070	Fax: +1-815-397-9247

4455 Boeing Drive • Rockford, IL 61109-2988 • USA • 815-397-7070  
An ISO 9001 Company • Greenlee Textron Inc. is a subsidiary of Textron Inc.

[www.greenlee.com](http://www.greenlee.com)

Printed in USA