

INSTRUCTION MANUAL

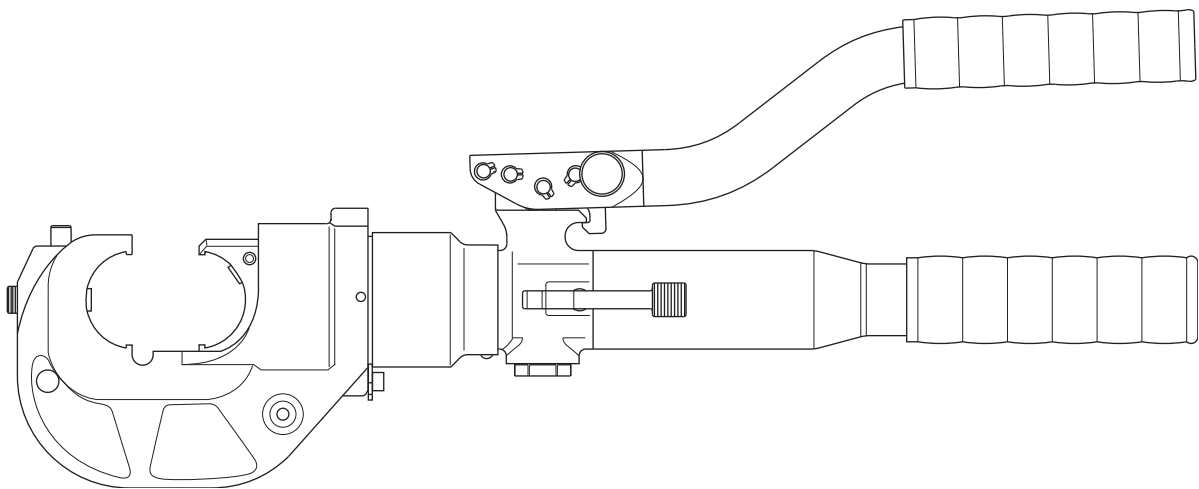

HK1230 and HK1230C Hydraulic Crimping Tools



Read and understand all of the instructions and safety information in this manual before operating or servicing this tool.

Register this product at www.greenlee.com

Table of Contents

Description	2
Safety	2
Purpose of this Manual	2
Important Safety Information	3-4
Identification	5
Specifications	5
Operation	6
Die Selection	7
Connector Selection	7
Periodic Pressure Relief Valve Check	8
Illustrations and Parts List	9-12

Description

The HK1230 Hydraulic Crimping Tool is a hand-held, self-contained crimping tool intended to crimp aluminum and copper connectors onto electrical cable. It uses industry standard 12-ton U type dies, purchased separately.

The HK1230C has a PVC-covered crimping head.

Safety

Safety is essential in the use and maintenance of Greenlee tools and equipment. This instruction manual and any markings on the tool provide information for avoiding hazards and unsafe practices related to the use of this tool. Observe all of the safety information provided.

Purpose of this Manual

This instruction manual is intended to familiarize operators and maintenance personnel with the safe operation, troubleshooting, and repair procedures for the Greenlee HK1230 and HK1230C.

Keep this manual available to all personnel.

Replacement manuals are available upon request at no charge at www.greenlee.com.

All specifications are nominal and may change as design improvements occur. Greenlee Textron Inc. shall not be liable for damages resulting from misapplication or misuse of its products.

KEEP THIS MANUAL



IMPORTANT SAFETY INFORMATION



**SAFETY
ALERT
SYMBOL**

This symbol is used to call your attention to hazards or unsafe practices which could result in an injury or property damage. The signal word, defined below, indicates the severity of the hazard. The message after the signal word provides information for preventing or avoiding the hazard.

⚠ DANGER

Immediate hazards which, if not avoided, **WILL** result in severe injury or death.

⚠ WARNING

Hazards which, if not avoided, **COULD** result in severe injury or death.

⚠ CAUTION

Hazards or unsafe practices which, if not avoided, **MAY** result in injury or property damage.



⚠ WARNING

Read and understand all of the instructions and safety information in this manual before operating or servicing this tool.

Failure to observe this warning could result in severe injury or death.



⚠ WARNING

Electric shock hazard:

This tool is not insulated. When using this unit on or near energized electrical lines, use proper personal protective equipment.

Failure to observe this warning could result in severe injury or death.

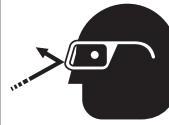

⚠ WARNING

Wear eye protection when operating this tool.

Failure to wear eye protection could result in serious eye injury from flying debris or hydraulic oil.



⚠ WARNING

Skin injection hazard:

- Do not use hands to check for leaks.
- Depressurize the hydraulic system before servicing.

Oil under pressure easily punctures skin causing serious injury, gangrene, or death. If you are injured by escaping oil, seek medical attention immediately.



IMPORTANT SAFETY INFORMATION

⚠ WARNING

An incomplete crimp can cause a fire.

- Use proper die, connector, and cable combinations. Improper combinations can result in an incomplete crimp.
- The handle load will drop suddenly to indicate a completed crimp. If the handle load does not drop suddenly, the crimp is not complete.

Failure to observe these warnings could result in severe injury or death.

⚠ WARNING

Inspect tool before use. Replace any worn or damaged parts. A damaged or improperly assembled tool can break and strike nearby personnel.

Failure to observe this warning could result in severe injury or death.

⚠ CAUTION

- This tool is intended for two-handed operation. Maintain a firm grip on both handles during operation. Using this tool in any other manner can result in injury or property damage.
- Do not operate the tool without a connector in place. Damage to the ram or crimping tool head can result.
- Do not perform any service or maintenance other than as described in this manual. Injury or damage to the tool may result.

Failure to observe these precautions may result in injury and property damage.

Note: Keep all decals clean and legible, and replace when necessary.



Identification

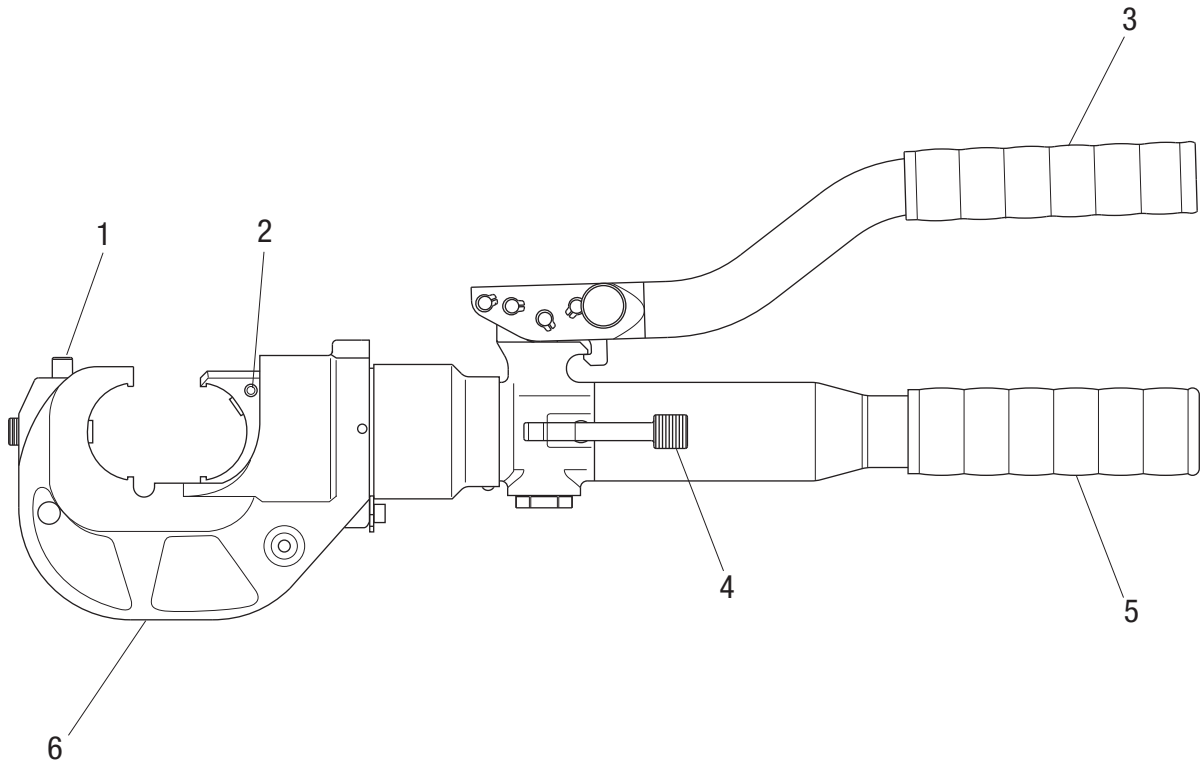

HK1230 and HK1230C

- | | |
|-----------------------|--------------------------|
| 1. Die Release Button | 4. Return Lever |
| 2. Die Release Button | 5. Handle with Reservoir |
| 3. Handle | 6. Crimping Head |

Specifications

Crimping Tool

Length 518 mm (20.4")
 Width 80 mm (3.1")
 Mass/Weight 5.5 kg (12.2 lb)
 Hydraulic Oil 50 ml (0.1 pint) biodegradable hydraulic fluid

Crimping Capacities

Crimping Range 8 AWG to 750 kcmil
 Crimping Force 106 kN (12 tons)



Operation

	⚠ WARNING
	<p>Electric shock hazard:</p> <p>This tool is not insulated. When using this unit on or near energized electrical lines, use proper personal protective equipment.</p> <p>Failure to observe this warning could result in severe injury or death.</p>

	⚠ WARNING
	<p>Wear eye protection when operating this tool.</p> <p>Failure to wear eye protection could result in serious eye injury from flying debris or hydraulic oil.</p>

	⚠ WARNING
	<p>Skin injection hazard:</p> <ul style="list-style-type: none"> Do not use hands to check for leaks. Depressurize the hydraulic system before servicing. <p>Oil under pressure easily punctures skin causing serious injury, gangrene, or death. If you are injured by escaping oil, seek medical attention immediately.</p>

⚠ WARNING
<p>An incomplete crimp can cause a fire.</p> <ul style="list-style-type: none"> Use proper die, connector, and cable combinations. Improper combinations can result in an incomplete crimp. The handle load will drop suddenly to indicate a completed crimp. If the handle load does not drop suddenly, the crimp is not complete. <p>Failure to observe these warnings could result in severe injury or death.</p>

- Clean the die seat area.
- Install the proper size and type of crimping dies.
- Press the release button on the C-head and slide one of the die halves into the jaw. Release the button and slide the die half until the retainer snaps and locks the die into place.
- Press the release button on the ram body (located in the cutout) and slide the other die half in. Release the button and slide the die half until the retainer snaps and locks the die into place.
- Follow the connector manufacturer's instructions for appropriate cable strip length and surface preparation.
- Insert cable fully into connector and center the connector between the dies.

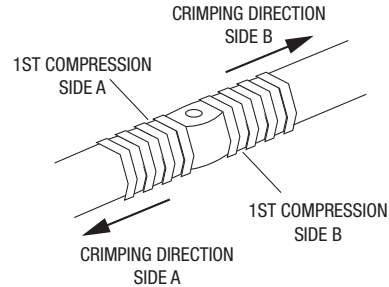
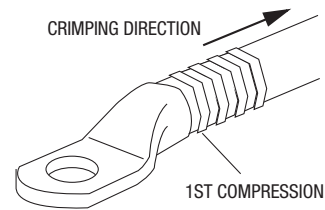

- Using the sequence illustrated here, pump the handles to advance the dies. Continue to pump until the pressure relief valve activates.

Note: Pressure relief occurs at approximately 106 kN (12 tons) and is indicated by an audible "pop".

- After achieving pressure relief, the ram automatically returns to the start position and the dies retract.
- When using KC12-type dies, complete the number of crimps listed on the "Connector Selection" chart in this manual. For other dies, complete the number of crimps specified by the manufacturer.
- Remove connector from crimping tool.
- Press the trigger lock upward to lock the trigger.

Note: After completing the last crimp on an aluminum connector, wipe off the excess oxide inhibitor.

Die Selection

Refer to “Connector Selection” for brand names and model numbers of appropriate lugs as well as crimping instructions. Crimps made with this tool and KC12-type or KA12-type dies are cUL and UL classified when used with the appropriate conductor and connectors listed below.

Dies for Copper Connectors

Catalog Number	UPC Number	Cable Size	Color Code	No. of Crimps
KC12-8	10996	8 AWG	Red	1
KC12-6	10997	6 AWG	Blue	1
KC12-4	10998	4 AWG	Gray	1
KC12-2	10999	2 AWG	Brown	1
KC12-1	11003	1 AWG	Green	1
KC12-1/0	11004	1/0 AWG	Pink	1
KC12-2/0	11007	2/0 AWG	Black	1
KC12-3/0	11010	3/0 AWG	Orange	1
KC12-4/0	11011	4/0 AWG	Purple	1
KC12-250	11012	250 kcmil	Yellow	1
KC12-300	11013	300 kcmil	White	2
KC12-350	11014	350 kcmil	Red	2
KC12-400	11015	400 kcmil	Blue	2
KC12-500	11016	500 kcmil	Brown	2
KC12-600	11018	600 kcmil	Green	2
KC12-750	11020	750 kcmil	Black	2

Dies for Aluminum Connectors

Catalog Number	UPC Number	Cable Size	Color Code	No. of Crimps
KA12-8	22084	8 AWG	Blue	1
KA12-6	22085	6 AWG	Gray	1
KA12-4	22086	4 AWG	Green	1
KA12-2	22087	2 AWG	Pink	1
KA12-1	22088	1 AWG	Gold	1
KA12-1/0	22089	1/0 AWG	Tan	1
KA12-2/0	22090	2/0 AWG	Olive	2
KA12-3/0	22121	3/0 AWG	Ruby	2
KA12-4/0	22122	4/0 AWG	White	2
KA12-250	22123	250 kcmil	Red	2
KA12-300	22124	300 kcmil	Blue	2
KA12-350	22125	350 kcmil	Brown	2
KA12-400	22126	400 kcmil	Green	3
KA12-500	22127	500 kcmil	Pink	3
KA12-600	22128	600 kcmil	Black	3
KA12-750	22129	750 kcmil	Yellow	3

Connector Selection (NOT for use with flex, navy, or welding wire)

Tool Range: 8 AWG to 750 kcmil

When used with KC12-type dies, this tool is cUL and UL classified for use with the following connector brands:

CONNECTOR TYPE	BARREL TYPE	ANDERSON	BLACKBURN®	BURNDY	ILSCO	PANDUIT	T&B	PENN-UNION	NUMBER OF CRIMPS*
Copper Splices	Short	VHSS	CSP	YS-L	CT	SCSS SCS	54504 to 54523-TB	BCU	8 AWG to 250 kcmil: 1 crimp 300 to 750 kcmil: 2 crimps
	Long	VHS	CU	YS	CTL	SCL SCH	54804 to 54823	BBCU	
Copper Lugs	Short	VHCS	CTL-2/CTL	YA-2LN/ YA-L/YA-2L; YA/YA-L-TC/ YA-L-2TC	CSW CRA/CRB CRC	LCAS LCA LCD LCAN	54104 to 54123-TB; 54204 to 54223	BLU	
	Long	VHCL	CTL-L/LCN	YA/YAZ YA-2N/YA-2TC YAZ-2N/YAZ-2TC	CLN, CLW CRA-L/CRB-L CRA-2/CRB-2L CRC-2L	LCB LCC	54930BE to 54923BE; 54850BE to 54880BE	BBLU	

When used with KA12-type dies, this tool is cUL and UL classified for use with the following connector brands:

CONNECTOR TYPE	ANDERSON	BLACKBURN®	BURNDY	ILSCO	PANDUIT	T&B	PENN-UNION	NUMBER OF CRIMPS*
Dual-rated Aluminum Splices	VACS	ASP	YS-A	AS	SA	60501 to 60578	PIK	8 to 1/0 AWG: 1 crimp 2/0 AWG to 350 kcmil: 2 crimps
Dual-rated Aluminum Lugs	VACL	ATL	YA-A YA-ATN	ACL/ACN 2ACL/2ACN	LAA LAB	60101 to 60176; 60230 to 60278	BLUA	400 to 750 kcmil: 3 crimps



* Use the number of crimps listed in this column instead of the number provided with the connector.



Periodic Pressure Relief Valve Check

	⚠ WARNING
	Pinch points: Keep hands away from closing dies. Failure to observe this warning could result in severe injury or death.

The crimping tool's relief valve may require occasional adjustment. To determine whether this adjustment is necessary, periodically test the crimping tool with a Greenlee model 35887 Load Cell (purchased separately).

1. Insert the test dies into the tool (refer to steps 3 and 4 under "Operation" in this manual). Position the load cell so that the load cell piston is centered between the two test dies.
2. Pump the lever until crimping tool achieves pressure relief and note the position of the needle when the pressure relief is achieved. The needle should indicate the "12T" range. If the needle is outside of this range, send the crimping tool to an authorized service center for adjustment.

Note: If some other type of load cell is used, the ratio between the area of the tool and the area of the load cell may be different. The appropriate corresponding pressure range depends upon this ratio.

Illustration

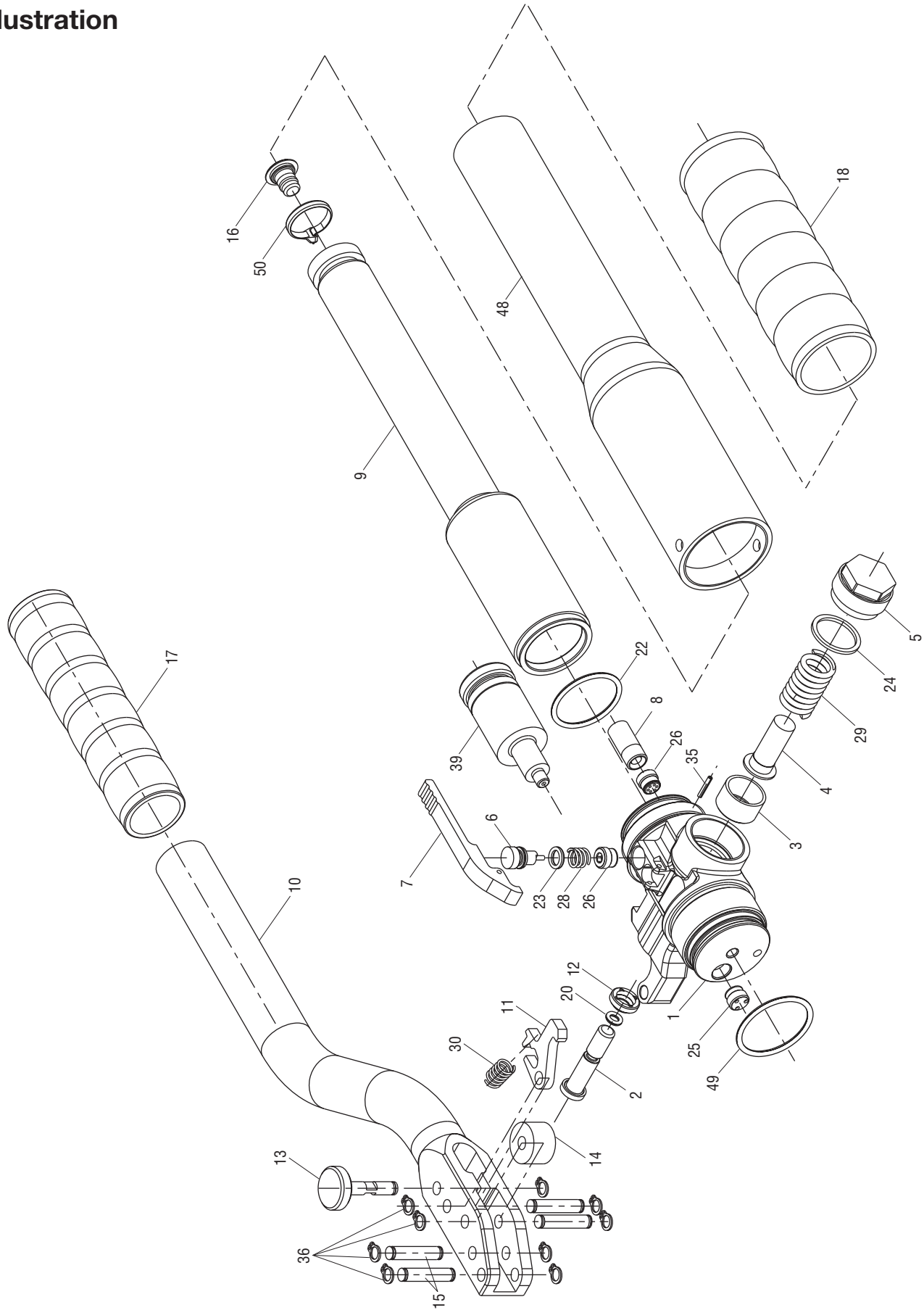

Illustration

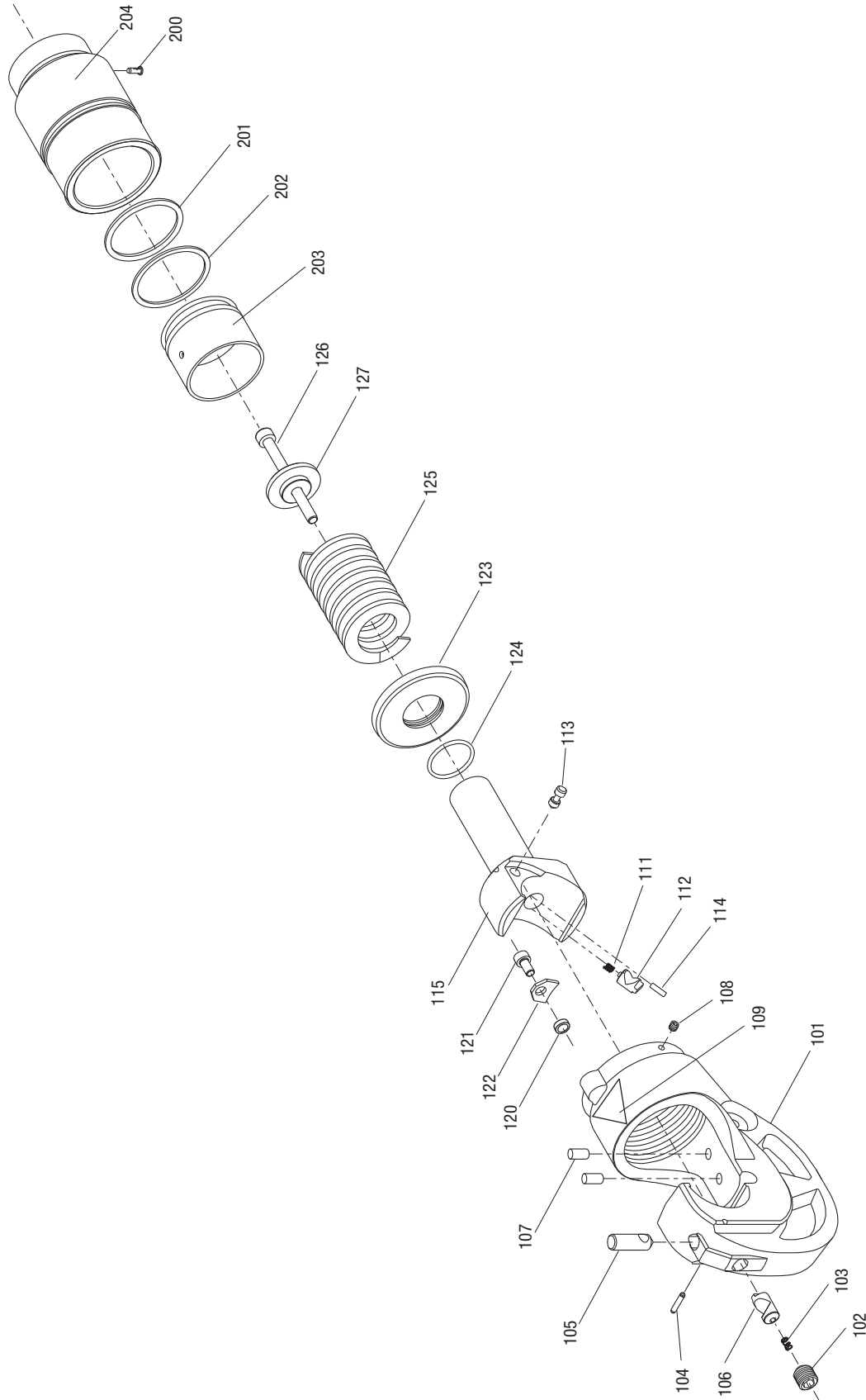



Parts List

Key	Part No.	Description	Qty
1	52046663	Body.....	1
2	50063456	Pump piston.....	1
3	50063464	Sleeve	1
4	52046664	Ram.....	1
5	50063499	Screw plug	1
6	52046669	Release pin	1
7	50063553	Release lever.....	1
8*		Filter	1
9	50063448	Reservoir.....	1
	52045246	Handle assembly (includes items 10–15, 17, 30, 36).....	1
10		Pump handle.....	1
11	52045245	Handle lock	1
12*		Piston seal.....	2
13	50063600	Release knob	1
14	50063618	Roller	1
15	50063642	Handle pin	4
16	50058789	Reservoir plug	1
17	50063421	Grip 25 mm	1
18	52060035	Grip	1
20*		O-ring.....	1
22*		O-ring.....	1
23*		O-ring.....	1
24*		Copper washer.....	1
25	50109308	Threaded bushing	1
26	50109162	Threaded bushing	2
28	52046667	Spring, compression.....	1
29	50063731	Spring, compression.....	1
30	50063740	Spring, extension	1
35*		Roll, pin	1
36*		Retaining ring.....	9
39	50063316	Pressure adjustment cartridge.....	1
48	50067826	Handle.....	1
49*		O-ring.....	1
50*		Ring tie	1
	50053728	C-head assembly 30 mm (includes items 101–109)	
	50072161	PVC-covered head assembly (includes items 101–109)	
101	50052594	Crimping head.....	1
	50072218	PVC-covered head.....	1
102		Set screw	1
103		Spring, compression.....	1
104		Groove pin.....	1
105		Die release button	1
106		Die release pin.....	1
107	90550625	Groove pin.....	2
108	90550617	Set screw	1
109	50062140	Decal, pinch hazard	1



Parts List (cont'd)

Key	Part No.	Description	Qty
	50053779	Ram-spring assembly 30 mm (includes items 111–115)	
111		Spring, compression.....	1
112		Die release pin.....	1
113		Release shaft	1
114		Spring pin.....	1
115		Ram.....	1
120	50066960	Bushing.....	1
121	50043676	Screw M5 X 10.....	1
122	50066943	Stop.....	1
123	50066927	Spring stop.....	1
124	50066935	O-ring	1
125	50066919	Ram spring.....	1
126	50066951	Screw M6 X 70.....	1
127	50066900	Disc	1
200	50058720	Screw	1
201*		O-ring	1
202*		Backup ring.....	1
203	50067796	Piston	1
204	50067850	Cylinder tube.....	1
	50065017	Decal, ID and warning	
	50067109	Carrying case	
	50112171	Decal, connector capability	
	52055068	Wrench, bushing	
	52057878	Biodegradable hydraulic fluid (1 qt)	
*	50067907	Seal kit (includes items marked with an asterisk)	
	52060036	Pin kit, head (includes items 102–106)	

