

INSTRUCTION MANUAL

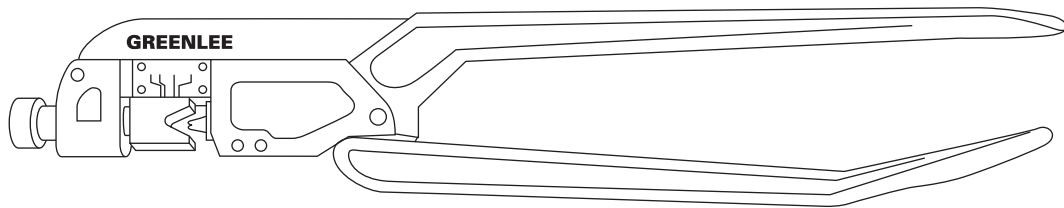

1981 Mechanical Crimping Tool



Read and understand all of the instructions and safety information in this manual before operating or servicing this tool.

Register this product at www.greenlee.com

Description

The 1981 Mechanical Crimping Tool is intended for crimping copper color-coded lugs and splices from 8 AWG through 250 kcmil and aluminum color-coded lugs and splices from 6 AWG through 4/0 AWG.

Safety

Safety is essential in the use and maintenance of Greenlee tools and equipment. This instruction manual and any markings on the tool provide information for avoiding hazards and unsafe practices related to the use of this tool. Observe all of the safety information provided.

Purpose of this Manual

This manual is intended to familiarize all personnel with the safe operation and maintenance procedures for the following Greenlee tool:

1981 Mechanical Crimping Tool

Keep this manual available to all personnel.

Replacement manuals are available upon request at no charge at www.greenlee.com.

Important Safety Information

	⚠ WARNING
	<p>Electric shock hazard: This tool is not insulated. Do not use on live circuits. Contact with live circuits could result in severe injury or death.</p>

⚠ WARNING
<p>An incomplete crimp can cause a fire. Use proper connector and cable combinations. Improper combinations can result in an incomplete crimp. Failure to observe this warning could result in severe injury or death.</p>

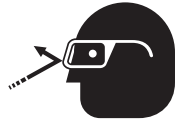
	⚠ WARNING
	<p>Wear eye protection when operating or servicing this tool. Failure to wear eye protection could result in serious eye injury from flying debris.</p>

⚠ CAUTION
<ul style="list-style-type: none"> • This tool is intended for two-handed operation. Maintain a firm grip on both handles when using this tool. • Inspect tool before use. If any parts are worn or damaged, send the tool to an authorized Greenlee service center. • Do not perform any service or maintenance other than as described in this manual. • Do not exceed the rated capacity of this tool. <p>Failure to observe these precautions may result in injury or property damage.</p>

All specifications are nominal and may change as design improvements occur. Greenlee Textron shall not be liable for damages resulting from misapplication or misuse of its products.

Blackburn is a registered trademark of Thomas & Betts.

KEEP THIS MANUAL

Identification

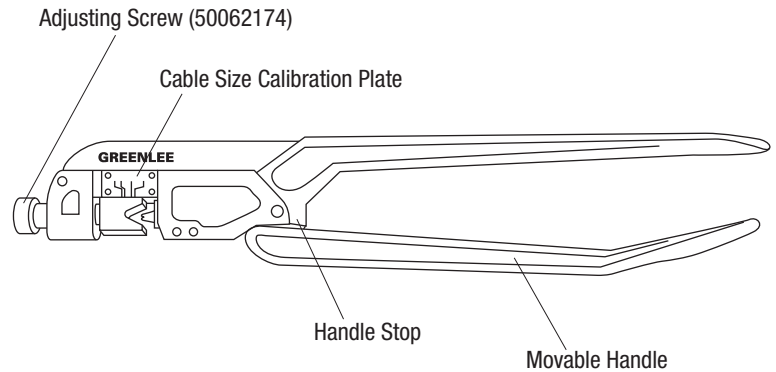
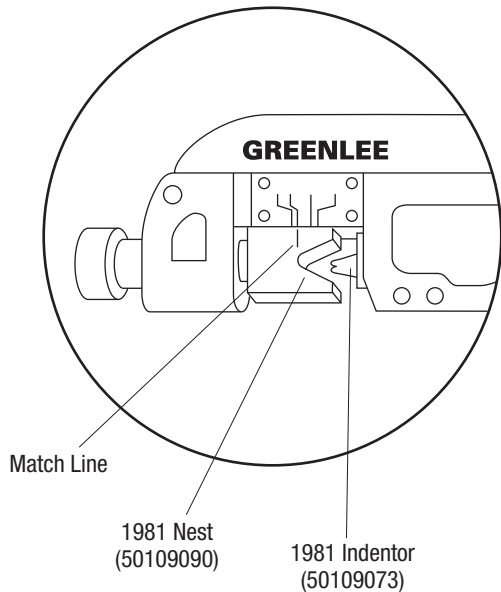

Note: Do not remove the calibration plates from the sides of the crimper frame.

Operation

1. Refer to the connector manufacturer's instructions for preparing the cable and connector.
2. Set the nest (adjustable die) of the crimping tool to the proper cable size by turning the adjusting screw at the top of the crimping tool until the match line on the nest is aligned with the proper cable size.
3. Consult the Connector Selection chart for recommended number of crimps.
4. Insert cable and connector assembly from either side of the crimping tool and indent as instructed by the connector manufacturer. To ensure a proper crimp, close the handles until the movable handle rests against the stop of the other handle.

Calibration Check

Set the match line on the nest to indicate 1/0 wire. To determine if the crimping tool is properly calibrated, insert a metal rod that fits snugly between the nest and indicator. If the metal rod is within the range shown on the Calibration Table, the crimping tool is correctly calibrated.

If the diameter is not within this range, send the tool to an authorized Greenlee service center.

Calibration Table

Set 1/0 CU to

	Minimum	Maximum
Metal Rod	0.353"	0.373"
	9.0 mm	9.5 mm

Set 1/0 AL to

	Minimum	Maximum
Metal Rod	0.422"	0.442"
	10.7 mm	11.2 mm

Connector Selection

CONNECTOR TYPE	BARREL TYPE	ANDERSON	BLACKBURN®	BURNDY	ILSCO	PANDUIT	T&B	PENN-UNION	NUMBER OF CRIMPS*
Tool Range—COPPER: 8 AWG to 250 kcmil (except as noted Δ)									
COPPER SPLICE	SHORT	VHSS	CSP	YS-L	CT	SCSS/SCS	54504–54513	BCU	A
	LONG	VHS	CU	YS-L	CTL	SCL	54804–54813	BBCU	A
COPPER LUG	SHORT	VHCS	CTL	YA-L/YA-L-2TC YA-2LN/YA-L-2NT	CSW ^Δ CRA/CRB/CRC	LCAS/LCA LCD/LCAN	54104–54174 54204–54275	BLU	A
	LONG	VHCL	CTL-L/LCN	YA/YAZ YA-2N/YA-2TC YAZ-2N/YAZ-2TC	CLN, CLW ^Δ CRA-L/CRB-L/CRA-2L CRB-2L/CRC-2L	LCB/LCC	54929BE–54913BE 54850BE–54868BE	BBLU	A
Tool Range—ALUMINUM: 6 AWG to 4/0 AWG									
AL SPLICE		VACS	ASP	YS-A	AS/ASN	SA	60507–60548	BCUA	B
AL LUG		VACL	ATL	YA-A/YA-A-TN	ACL/ACN 2ACL/2ACN ALNS/ALNN/ALND	LAA/LAB	60101–60157 60230–60250	BLUA	B

Δ ILSCO Capacity: 8 AWG to 4/0 AWG



***Use the number of crimps listed in the last column instead of the number provided with the connector:**

A — 8–1 AWG: 1 crimp
1/0 AWG–250 kcmil: 2 crimps

B — 6–4 AWG: 1 crimp
2–4/0 AWG: 2 crimps