

SERVICE MANUAL

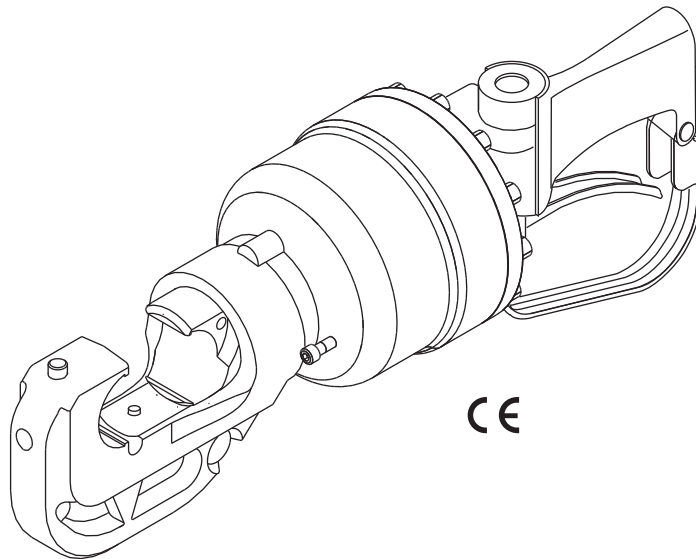

LPK1240

Hydraulic Crimping Tool

12-ton

Serial Code FYD



Read and understand all of the instructions and safety information in this manual before operating or servicing this tool.

Register this product at www.greenlee.com

Table of Contents

Safety	2
Purpose of this Manual	2
Other Publications	2
Important Safety Information	3-4
Relief Valve Check and Adjustment Procedure.....	5
Tool Setup	5
Disassembly	6
Inspection	6
Assembly	7
Illustration	8
Parts List	9

Safety

Safety is essential in the use and maintenance of Greenlee tools and equipment. This manual and any markings on the tool provide information for avoiding hazards and unsafe practices related to the use of this tool. Observe all of the safety information provided.

Purpose of this Manual

This manual is intended to familiarize all personnel with the safe service procedures for the following Greenlee Utility tool:

LPK1240 (49345) Serial Code FYD

Keep this manual available to all personnel.

Replacement manuals are available upon request at no charge at www.greenlee.com.

Other Publications

Instruction Manual: Publication 99932245

SAE Standard J1273 (Hose and Hose Assemblies):
Publication 99930323

All specifications are nominal and may change as design improvements occur. Greenlee Textron Inc. shall not be liable for damages resulting from misapplication or misuse of its products. Loctite and 242 are registered trademarks of Loctite Corporation.

KEEP THIS MANUAL

IMPORTANT SAFETY INFORMATION



**SAFETY
ALERT
SYMBOL**

This symbol is used to call your attention to hazards or unsafe practices which could result in an injury or property damage. The signal word, defined below, indicates the severity of the hazard. The message after the signal word provides information for preventing or avoiding the hazard.

⚠ DANGER

Immediate hazards which, if not avoided, **WILL** result in severe injury or death.

⚠ WARNING

Hazards which, if not avoided, **COULD** result in severe injury or death.

⚠ CAUTION

Hazards or unsafe practices which, if not avoided, **MAY** result in injury or property damage.



⚠ WARNING

Read and understand all of the instructions and safety information in this manual before operating or servicing this tool. Refer also to the Instruction Manual, which is listed under "Other Publications."

Failure to observe this warning could result in severe injury or death.



⚠ WARNING

Skin injection hazard:

- Do not use hands to check for leaks.
- Do not hold hose or couplers while the hydraulic system is pressurized.
- Depressurize the hydraulic system before servicing.

Oil under pressure easily punctures skin, causing serious injury, gangrene, or death. If you are injured by escaping oil, seek medical attention immediately.

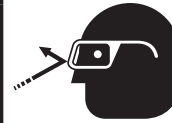

⚠ WARNING

Wear eye protection when operating or servicing this tool.

Failure to wear eye protection could result in serious eye injury from flying debris or hydraulic oil.



⚠ WARNING

Wear hearing protection when using this tool.

Long-term exposure to high noise levels could result in hearing loss.



⚠ WARNING

The hydraulic cylinder may be hot during and after operation. Hot surfaces can cause serious burns.



⚠ WARNING

Keep hands away from dies when crimping.

Failure to observe this warning could result in severe injury or death.

IMPORTANT SAFETY INFORMATION

⚠ WARNING

Do not exceed the following hydraulic power source maximums:

- Hydraulic flow: 34.1 l/min (9 gpm).
- Pressure relief setting: 172 bar (2500 psi).
- Back pressure: 13.8 bar (200 psi)

Failure to observe this warning could result in severe injury or death.

⚠ WARNING

Do not disconnect tool, hoses or fittings while the power source is running or if the hydraulic fluid is hot. Hot hydraulic fluid can cause serious burns.

⚠ WARNING

Do not reverse hydraulic flow. Operation with hydraulic flow reversed can cause tool malfunction. Connect the pressure (supply) hose and tank (return) hose to the proper tool ports.

Failure to observe this warning could result in severe injury or death.

⚠ WARNING

Do not change accessories, inspect, adjust, or clean tool when it is connected to a power source. Accidental start-up can result in serious injury.

Failure to observe this warning can result in severe injury or death.

⚠ CAUTION

Hydraulic oil can cause skin irritation.

- Handle the tool and hoses with care to prevent skin contact with hydraulic oil.
- In case of accidental skin contact with hydraulic oil, wash the affected area immediately to remove the oil.

Failure to observe these precautions may result in injury.

IMPORTANT

Procedure for connecting or disconnecting hydraulic hoses, fittings, or components:

1. Move the flow lever on the hydraulic power source to the OFF position.
2. Stop the hydraulic power source.
3. Follow the sequence under “Hose Connections” in the Instruction Manual to prevent pressure buildup. In case some pressure has built up, loosen hoses, fittings, or components slowly.

Note: Keep all decals clean and legible, and replace when necessary.

When disposing of any components (hydraulic hoses, hydraulic fluid, worn parts, etc.), do so in accordance with federal, state, and local laws or ordinances.

Relief Valve Check and Adjustment Procedure

- Use one of these methods for checking the setting of the relief valve:
 - Purchase a Greenlee 35887 Load Cell. Refer to the instructions supplied with the load cell. The proper relief pressure is within the 12-ton range indicated on the gauge.
 - Install an in-line pressure gauge at the tool's input. With dies in place, perform a test crimp. The proper relief pressure range is 103 bar to 107 bar (1500 psi to 1550 psi).
- To change the setting, remove the cap (50) and rotate the set screw (48):
 - clockwise to increase the relief pressure
 - counterclockwise to decrease the relief pressure

Note: The copper washer (49) may fall free when the cap (50) is removed.
- Install the copper washer (49) and cap (50). Without changing the setting of the set screw (48), tighten the cap.
- Perform three more test crimps to be sure that the relief valve setting was not disturbed during Step 3.

Tool Setup

This tool can be used on either open-center or closed-center hydraulic systems.

Open-Center Setting

- With the ram retracted, disconnect the crimping tool from the hydraulic power source.
- Loosen the two seal nuts. Back each seal nut out to the end of the screw.
- Turn the screws clockwise — evenly, alternating every one to two turns — until they contact the piston and feel snug.
- Back the screws out — evenly, alternating every one to two turns — exactly four complete turns.
- Hold the screws in place with an Allen wrench and tighten the seal nuts against the cover. Torque the seal nuts to 6.78 newton-meters (5 foot-pounds).

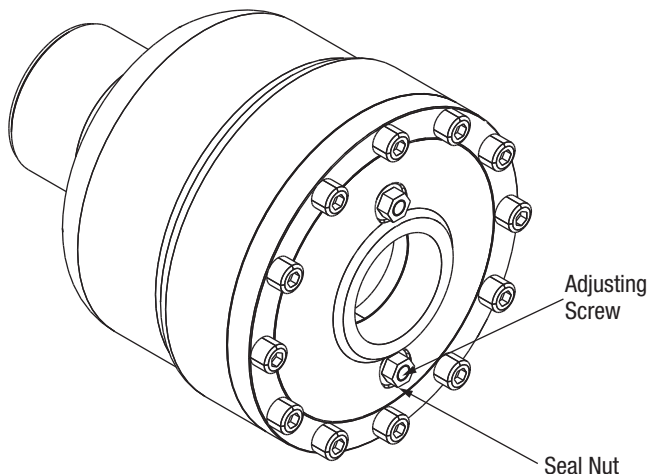

Closed-Center Setting

- Disconnect the crimping tool from the hydraulic power source.
- Loosen the two seal nuts.
- Turn the screws counterclockwise — evenly, alternating every one to two turns — until they contact the stops.
- Hold the screws in place with an Allen wrench and tighten the seal nuts against the cover. Torque the seal nuts to 6.78 newton-meters (5 foot-pounds).

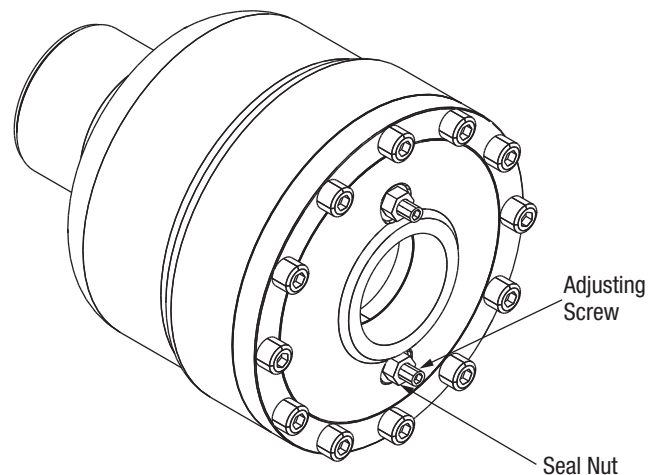

Installing Dies

- Clean the die seat area.
- Install the proper size and type of crimping dies.

Disassembly

Complete disassembly of the tool is not recommended. If a complete overhaul is necessary, return the tool to your nearest authorized Greenlee Utility distributor or to Greenlee.

The disassembly procedure is divided into sections of the tool. Disassemble only the section(s) necessary to complete the repair.

Disassemble the tool on a flat, clean surface. Take care not to lose or damage any parts that may fall free during disassembly.

Handle

1. Remove four screws (31) and the trigger strap (30).
2. Remove one retaining ring (34) and slide the trigger pivot pin (33) out of the handle assembly (26). Remove the trigger (32).
3. Remove 12 screws (27) and cover (20) from the cylinder (6). Remove the O-rings (74, 19).
4. Remove the retaining ring (28) from the handle assembly (26). Remove the tube assembly (22) and O-ring (24).
5. Opposite the trigger side of the handle, remove the retaining ring (40), spring cap (39), and spring (37).
6. On the trigger side of the handle, remove the retaining ring (40) and washer (36). Remove the spool assembly (41) toward the trigger side. Remove the spool groove O-ring (35) from the spool.
7. Opposite the trigger side, remove the spool OD O-ring (38) from the handle.
8. Remove cap (50), copper washer (49), adjusting screw (48), spring (47), and valve pin (46) from the handle.
9. Remove retaining ring (73), ball stop (72), and ball (71).
10. Remove pipe plugs (45).
11. If necessary, disassemble the shuttle stop ring (14) from the cover (20): Remove the seal nuts (44). Then turn the screws (15) evenly — alternating every one to two turns — until they disengage from the cover (20). Remove the retaining rings (16) and screws (15) from the shuttle stop ring.
12. If necessary, remove the handle (26) from the cover (20) by using low heat to break loose the thread locking compound that holds them together. Remove the handle (26), shims (21), and O-ring (29).

Cylinder and Ram

1. Remove four screws (51) and washers (70). Thread two 5/16-18 screws (not provided) into the tapped holes in the piston (7). Grasp these screws to pull the piston out of the cylinder.
2. Remove the piston seal (18), backup ring (17) and O-ring (24) with backup rings (25) from the piston.
3. Remove two screws (13), washers (12), and shuttle spools (11) from the piston.
4. Remove the rotational stop screw (5) from the cylinder (6).
5. Remove the C-head assembly (1) from the cylinder.
6. Remove the ram assembly (2), washer (3), and wiper (4) from the cylinder.
7. Remove the O-ring (10) and backup ring (9) from the ram (2).

Inspection

Clean all parts with solvent and dry them thoroughly. Inspect each component, and replace any that shows wear or damage.

Assembly

Refer to the illustration and parts list for the correct orientation and placement of parts.

Replace any O-rings, V-rings, seals, and gaskets on parts that have been disassembled. Apply hydraulic fluid or O-ring lubricant to all O-rings and all metal surfaces which they must slide over. When installing an O-ring which must slide over sharp surfaces, use a rolling motion and be careful not to damage the O-ring.

Wherever the assembly results in metal-to-metal contact, coat the surfaces with hydraulic fluid or O-ring lubricant.

Some steps of the assembly procedure require a removable type of thread sealing and locking compound, such as Loctite® 242® or equivalent. Follow the manufacturer's instructions for curing.

Cylinder and Ram

1. Install O-ring (10), backup ring (9), wiper (4), and washer (3) onto the ram (2).
2. Slide the ram assembly into the cylinder (6) until it bottoms out.
3. Screw the C-head assembly (1) onto the cylinder (6) until the flat surface of the C-head is flush with the similar flat surface of the ram.

Screw the C-head to the cylinder until these surfaces are flush.

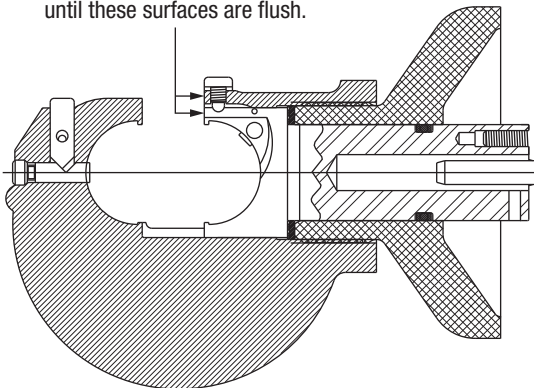

4. Apply a thread locking compound to the rotational stop screw (5) and install it into the cylinder (6).
5. Install backup ring (17), seal (18), and O-ring (24) with backup rings (25) onto the piston (7).
6. Apply a thread locking compound to the screws (13). Install shuttle spools (11), washers (12), and screws (13). Remove excess compound after assembly and apply a thin coat of oil to the surrounding area.
7. Apply a thread locking compound to the threaded holes of the ram — one bead of compound along the entire length of the thread. Install the piston (7) into the cylinder (6) and secure it to the ram assembly (2) using screws (51) with washers (70). Torque to 16.9 newton-meters (150 inch-pounds).

Handle with Cylinder Cover

1. Install the ball (71), ball stop (72), and retaining ring (73).
2. Install two 1/8" pipe plugs (45) into the handle (26).
3. Install the O-ring (24) onto the tube assembly (22). Slide the tube assembly into the handle (26) and secure it with the retaining ring (28).
4. Install the spool OD O-ring (38) into the handle, and install the spool groove O-ring (35) onto the spool (41). From the trigger side, install the spool assembly (41) into the handle (26).
5. Opposite the trigger side, install the spring (37) and spring cap (39), and secure them with a retaining ring (40).
6. From the trigger side, install the stop washer (36) and retaining ring (40) into the handle.
7. Install the valve pin (46), spring (47), adjusting screw (48), copper washer (49) and cap (50) into the handle.
8. Screw the handle assembly (26) into the cover (20) until it is snug. Add or remove shims (21) — six maximum — to allow access to the stop ring adjustment screws (15) and nuts (44). After installing the proper number of shims, install the O-ring (29). Reassemble using a thread locking compound on the threads that mate the handle to the cover.
9. If removed, assemble the screws (15) to the shuttle stop ring (14) and secure them with the retaining rings (16). Install that assembly to the cover (20) and start the seal nuts (44) onto the screws (15).
Note: The setting of the screws (15) isn't important now — you will adjust them to the proper position later in the assembly procedure.
10. Assemble the O-rings (74, 19) to the cover (20).
11. Install the cover (20) into the cylinder (6), aligning the handle with the C-head. Secure with 12 cap screws (27). Torque to 32.5 newton-meters (24 foot-pounds).
12. Position the trigger (32) onto the handle (26), aligning the holes. Install the trigger pivot (33) and secure it with 5/32" external retaining rings (34). Position the trigger strap (30) onto the handle and secure it with four screws (31).

Final Settings

1. If the shuttle stop ring (14) was removed, refer to "Tool Setup" to adjust it to its previous position (for either open-center or closed-center operation).
2. Set the relief valve to the proper pressure. Refer to "Relief Valve Check and Adjustment Procedure."

Illustration

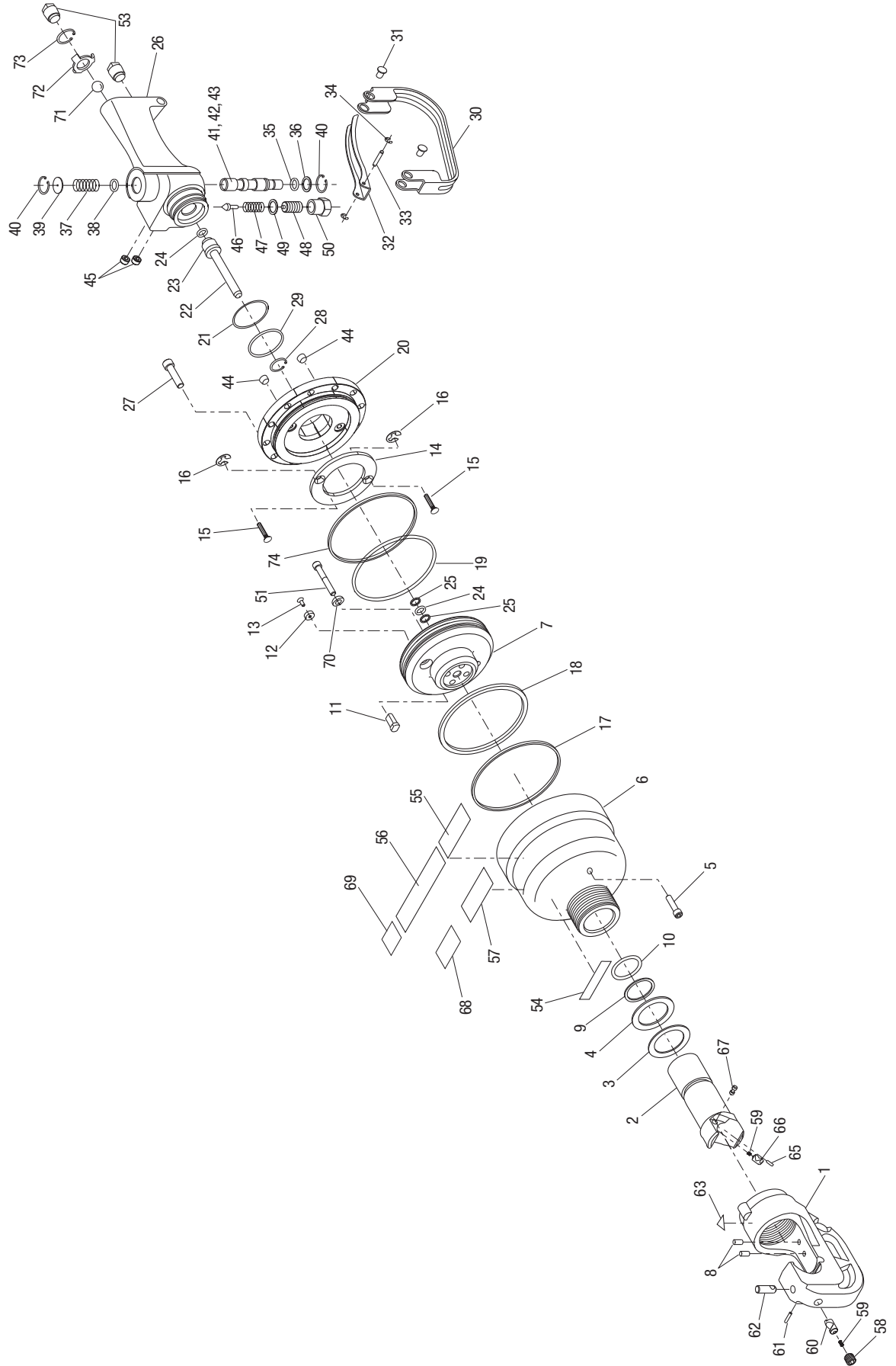

Parts List

UPC No.					UPC No.				
Key	78-3310-	Part No.	Description	Qty	Key	78-3310-	Part No.	Description	Qty
1	49348	50493485	C-head unit (includes items 8, 58-63).....	1	42	43556	50435566	Plug, spool.....	1
2	49112	50491121	Ram.....	1	43*			O-ring, .250 x .375 x .062"-90.....	1
3*			Washer, ram.....	1	44*			Nut, 1/4-20, Hydra-Lok seal.....	2
4*			Wiper, ram.....	1	45			Plug, pipe, 1/8" NPTF.....	2
5			Screw, cap, 1/4-20 x .87", socket head.....	1	46	30146	50301462	Pin, valve, .305 x .870".....	1
6	49349	50493493	Cylinder (includes items 54-57, 68, 69).....	1	47	40692	50406921	Spring, unloading valve.....	1
7	48733	50487337	Piston.....	1	48	48261	50482610	Screw, set, 1/2-20, adjusting.....	1
8	55062	90550625	Pin, groove (6 mm x 12 mm).....	2	49*			Washer, flat, .514 x .030, copper.....	1
9*			Backup ring, 1.375 x 1.62 x .121".....	1	50	48260	50482602	Cap, relief valve.....	1
10*			O-ring, 1.375 x 1.62 x .125".....	1	51			Screw, cap, 1/4-20 x 1.625, socket.....	4
11	43546	50435469	Spool, shuttle.....	2	53	41432	50414323	Plug, port.....	2
12	43547	50435477	Washer, shuttle.....	2	54	49947	50499475	Decal, press/flow.....	1
13			Screw, cap, #6-32 x .375", flat head socket.....	2	55	48734	50487345	Decal, OC/CC setting.....	1
14	48727	50487272	Ring, shuttle stop.....	1	56	49946	50499467	Decal, warning.....	1
15	48728	50487280	Screw, stop ring.....	2	57	41547	50415471	Decal, Greenlee Utility.....	1
16*			Retaining ring.....	2	58	55060	90550609	Screw, M12-1.75 x 12 mm set.....	1
17*			Backup ring, 4.312 x 4.500 x .125.....	1	59	03821	50038214	Spring.....	2
18*			Seal unit.....	1	60	05319	50053191	Pin, die retainer.....	1
19*			O-ring.....	1	61	55063	90550633	Pin, grooved, 3 mm x 16 mm.....	1
20	45659	50456598	Cover, cylinder.....	1	62	05317	50053175	Button, die release.....	1
21	48737	50487370	Shim, handle.....	6 (max)	63	06214	50062140	Decal, pinch warning.....	1
22	43554	50435540	Tube.....	1	65	55064	90550641	Pin, roll 3 mm x 10 mm.....	1
23	42685	50426851	Carrier, seal.....	1	66	05316	50053167	Pin, die retainer.....	1
24*			O-ring, .375 x .500 x .062"-70.....	2	67	05318	50053183	Button, die release.....	1
25*			Backup ring, .382 x .486 x .045".....	2	68	49506	50495062	Decal, CE.....	1
26	48736	50487361	Handle.....	1	69	49959	50499599	Decal, sound.....	1
27			Screw, cap, 5/16-18 x 1.25", socket head.....	12	70	54913	90549139	Washer, conical, .55 x .25 x .05.....	4
28*			Retaining ring, .750".....	1	71	41873	50418730	Ball, steel, .5".....	1
29*			O-ring, 1.625 x 1.750 x .062"-70.....	1	72	49234	50492349	Stop, ball.....	1
30	43699	50436996	Strap, trigger.....	1	73	41600	50416003	Retaining ring, .687.....	1
31			Screw, cap, #10-32 x .375", button socket head.....	4	74*			Backup ring.....	1
32	42576	50425760	Trigger.....	1	Repair Kit				
33	42547	50425471	Pivot, trigger.....	1	* 49343	50493434		Packing kit (includes items marked with an asterisk).....	1
34*			Retaining ring.....	2	Decals				
35*			O-ring, .437 x .562 x .062"-68.....	1	49947	50499475		Decal, press/flow.....	1
36	43401	50434012	Washer, .75 x .50 x .03.....	1	48734	50487345		Decal, OC/CC setting.....	1
37	42865	50428651	Spring, valve plunger.....	1	49946	50499467		Decal, warning.....	1
38*			O-ring, .562 x .750 x .093"-68.....	1	41547	50415471		Decal, Greenlee Utility.....	1
39	41095	50410952	Cap.....	1	06214	50062140		Decal, pinch warning.....	1
40*			Retaining ring, .750".....	2	49506	50495062		Decal, CE.....	1
41		52063245	Spool.....	1	49959	50499599		Decal, sound.....	1



4455 Boeing Drive • Rockford, IL 61109-2988 • USA • 815-397-7070
An ISO 9001 Company • Greenlee Textron Inc. is a subsidiary of Textron Inc.

www.greenlee.com

USA Tel: 800-435-0786
Fax: 800-451-2632

Canada Tel: 800-435-0786
Fax: 800-524-2853

International Tel: +1-815-397-7070
Fax: +1-815-397-9247