

# INSTRUCTION MANUAL

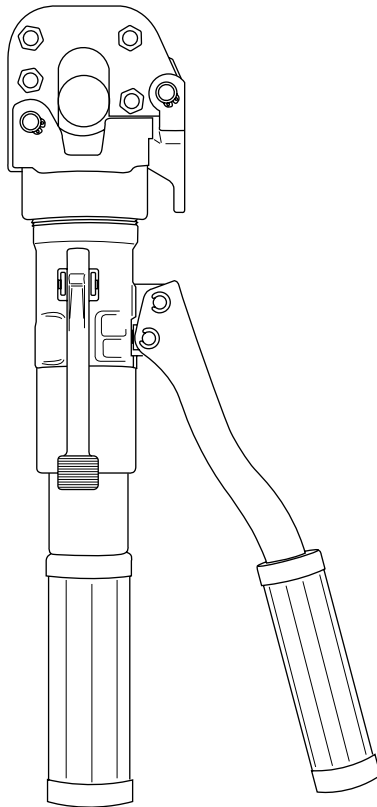

## HK520 Hydraulic Cable Cutter



**Read and understand** all of the instructions and safety information in this manual before operating or servicing this tool.

## Table of Contents

Description .....	2
Safety .....	2
Purpose of this Manual .....	2
Important Safety Information .....	3-4
Operation .....	5
Maintenance .....	6
Troubleshooting .....	7
Exploded View .....	8
Parts List .....	9

## Description

The HK520 Cable Cutter is intended to cut copper and aluminum cable up to 350 MCM, 397 ACSR, 1/2" reinforcement bar (rebar), 1/2" guy wire and 3/4" wire rope. It is not intended for use on EHS guy wire.

## Safety

Safety is essential in the use and maintenance of Greenlee tools and equipment. This instruction manual and any markings on the tool provide information for avoiding hazards and unsafe practices related to the use of this tool. Observe all of the safety information provided.

## Purpose

This instruction manual is intended to familiarize personnel with the safe operation and maintenance procedures for the Greenlee HK520 Cable Cutter.

Keep this manual available to all personnel.

Replacement manuals are available upon request at no charge.

All specifications are nominal and may change as design improvements occur. Greenlee Textron shall not be liable for damages resulting from misapplication or misuse of its products.

***KEEP THIS MANUAL***

## IMPORTANT SAFETY INFORMATION



### SAFETY ALERT SYMBOL

This symbol is used to call your attention to hazards or unsafe practices which could result in an injury or property damage. The signal word, defined below, indicates the severity of the hazard. The message after the signal word provides information for preventing or avoiding the hazard.

#### ⚠️ DANGER

Immediate hazards which, if not avoided, **WILL** result in severe injury or death.

#### ⚠️ WARNING

Hazards which, if not avoided, **COULD** result in severe injury or death.

#### ⚠️ CAUTION

Hazards or unsafe practices which, if not avoided, **MAY** result in injury or property damage.



#### ⚠️ WARNING

**Electrical Shock Hazard:** This tool is not insulated. Use protective equipment when utilizing this unit near energized electrical lines. Failure to observe this warning could result in severe injury or death.

#### ⚠️ WARNING

- **Electrical Shock Hazard:** The owner of this cutter must be certain that all users of this tool are trained in the applicable safety codes and standards, as well as, in the safe use of this tool and its accessories.
- Do not cut cable under tension.
- This tool is intended for two-handed operation. Maintain a firm grip on both handles during operation.

Failure to observe these warnings could result in severe injury or death.

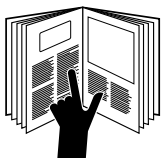

#### ⚠️ WARNING

Read and understand all of the instructions and safety information in this manual before operating or servicing this tool.

Failure to observe this warning will result in severe injury or death.

## IMPORTANT SAFETY INFORMATION

	<b>⚠ WARNING</b>
	<p>High Pressure Hazard: Do not use fingers or hands to check for oil leaks. High pressure oil easily punctures skin causing serious injury, gangrene or death. If injured seek medical help immediately to remove oil.</p>

	<b>⚠ WARNING</b>
	<p>Keep hands and fingers away from closing blades.</p>

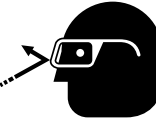
	<b>⚠ WARNING</b>
	<p>Wear eye protection when operating or servicing this tool. Failure to wear eye protection can result in serious eye injury from flying debris or hydraulic oil.</p>

<b>⚠ CAUTION</b>
<ul style="list-style-type: none"> <li>• Inspect the tool before use. Replace any worn or damaged parts. A damaged or improperly assembled tool can malfunction, injuring nearby personnel.</li> <li>• Do not perform any service or maintenance other than as described in this manual. Injury or damage to the tool may result.</li> <li>• Use this tool for the manufacturer's intended purpose only. Use other than that which is described in this manual could result in injury or property damage.</li> </ul>

<b>IMPORTANT</b>
<p>Do not place the tool in a vise. The cutter is designed for hand-held operation.</p>

## Operation

	<b>⚠ WARNING</b>
	<p>Electrical Shock Hazard: This tool is not insulated. Use protective equipment when utilizing this unit near energized electrical lines.</p> <p>Failure to observe this warning could result in severe injury or death.</p>

	<b>⚠ WARNING</b>
	<p>Keep hands and fingers away from closing blades.</p>

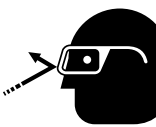
	<b>⚠ WARNING</b>
	<p>Wear eye protection when operating or servicing this tool.</p> <p>Failure to wear eye protection can result in serious eye injury from flying debris or hydraulic oil.</p>

<b>⚠ WARNING</b>
<ul style="list-style-type: none"> <li>Do not cut cable under tension.</li> <li>This tool is intended for two-handed operation. Maintain a firm grip on both handles during operation.</li> </ul> <p>Failure to observe these warnings could result in severe injury or death.</p>

<b>⚠ CAUTION</b>
<ul style="list-style-type: none"> <li>Inspect the tool before use. Replace any worn or damaged parts. A damaged or improperly assembled tool can malfunction, injuring nearby personnel.</li> <li>Do not perform any service or maintenance other than as described in this manual. Injury or damage to the tool may result.</li> <li>Use this tool for the manufacturer's intended purpose only. Use other than that which is described in this manual could result in injury or property damage.</li> </ul>

- Lift the head latch to open the cutter.
- Place the material to be cut between the jaws.
- Close the head latch completely.
- Align the material at a 90° angle to the blades.
- Pump the pump handle to advance the blade.
- When the cut is complete, press the release lever to retract the blade.

*Note: Do not continue to advance the blade after the cut is finished. This could cause the cable cutter to jam.*

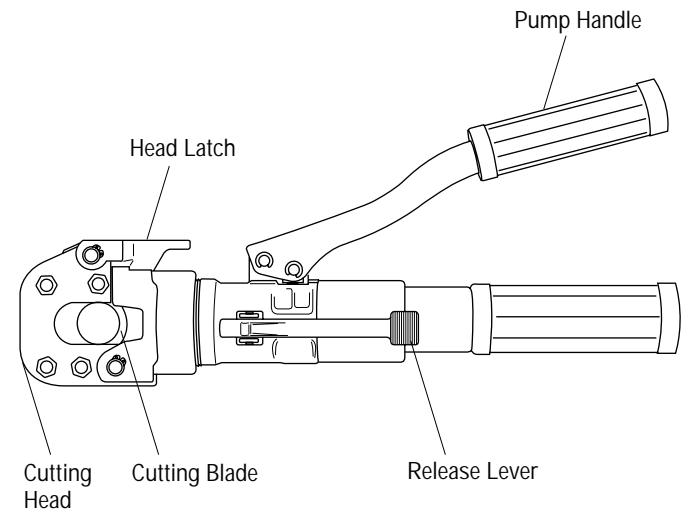

## Maintenance

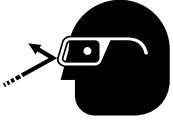
	<b>⚠ WARNING</b>
	<p>Wear eye protection when operating or servicing this tool.</p> <p>Failure to wear eye protection can result in serious eye injury from flying debris or hydraulic oil.</p>

<b>⚠ CAUTION</b>
<p>Do not perform any service or maintenance other than as described in this manual. Injury or damage to the tool may result.</p>

Use a spray lubricant to keep the cutting head free of grit, dirt and metal chips.

## Blade Sharpening Instructions

Edge should be flat

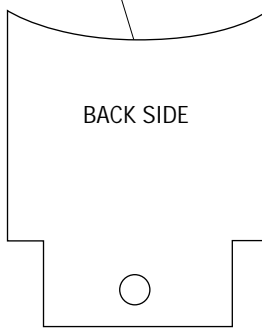

BACK SIDE

1. Set blade on flat surface with beveled edge facing down (see Figure A)
2. Use a sharpening stone to remove all burrs from back surface.

Figure A

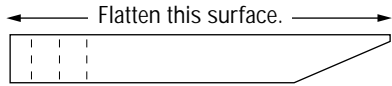

Flatten this surface.

Beveled Edge

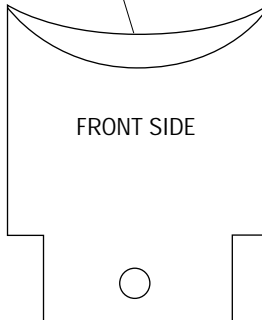

FRONT SIDE

3. Use a high-speed dremel-type tool to flatten top edge of blade (approximately 1/32" wide flat).

**Do not leave a sharp edge.** This will cause chipping of cutting surface and will decrease blade life.

## Troubleshooting

Problem	Probable Cause	Possible Remedy
Cutting blade does not advance. Ram advances but will not build enough pressure to cut.	<p>Check balls are not properly seated.</p> <p>Hydraulic fluid level is low, or there is air in the system.</p>	<p>Seat check ball (47) into induction valve (48).</p> <p>Remove main handle (55) exposing bladder (51). Remove plug (52). Fill with oil and replace plug (52).</p>
Blade does not retract after cut is completed.	Debris is caught between the moving blade and the cutter head.	<p>Unlatch the head. Press down on the release lever (31). Jog the head back and forth to free the blade. If the blade still doesn't retract, spray the head and moveable blade with a spray lubricant and repeat.</p>
Release lever (31) cannot be depressed.	Check ball will not unseat.	<p>Place the tip of a screwdriver directly on the release valve stem (34) under the release lever (31). Using the screwdriver as a lever, pull up on the screwdriver handle to depress the release ball stem.</p>
Blades do not cut cleanly.	Blades are dull.	<p>See blade sharpening instructions and diagrams.</p>

**Exploded View**

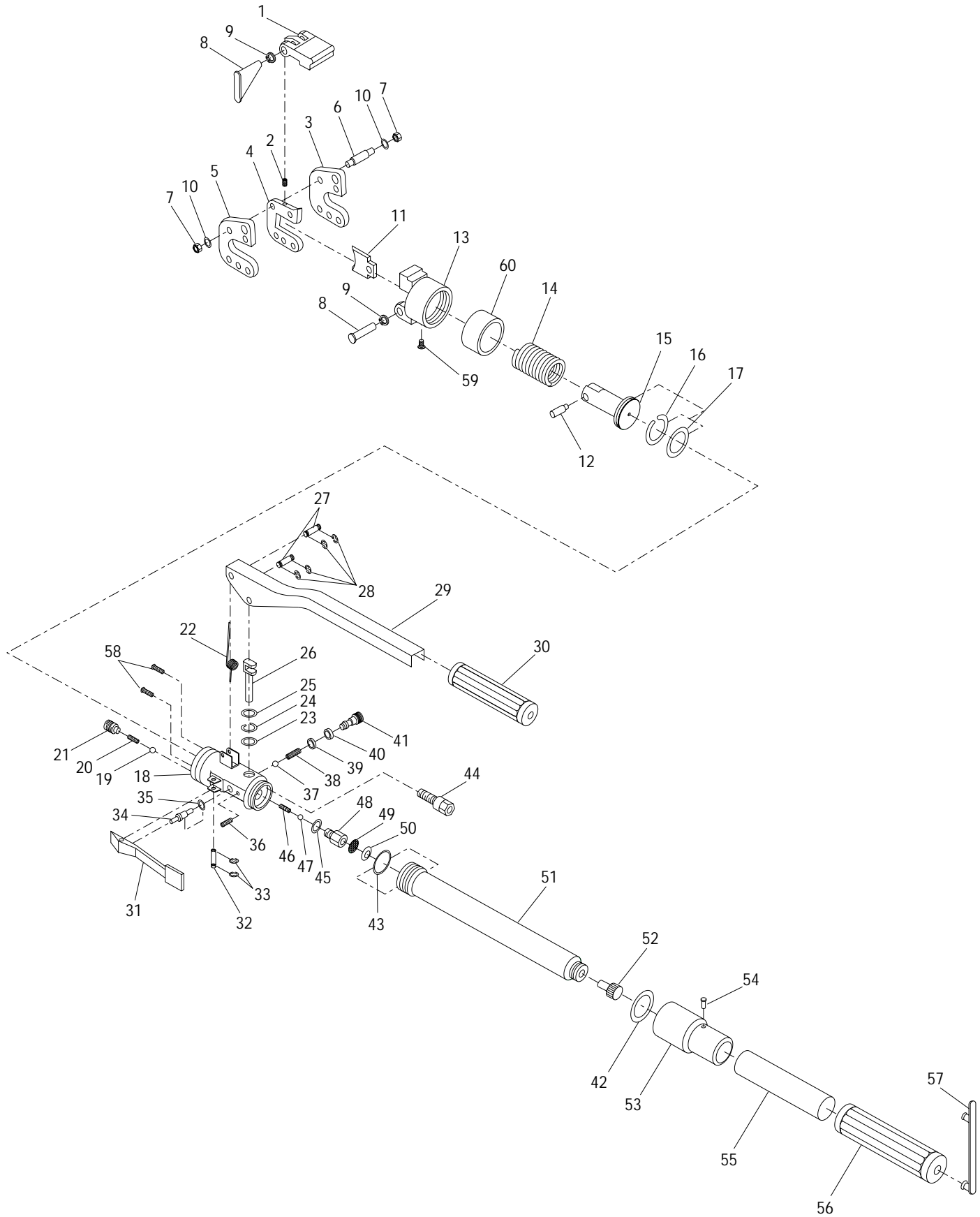



## Parts List

Key	Part No.	Description	Qty	Key	Part No.	Description	Qty
1	500 0333.0	Locking jaw .....	1	31	500 1019.0	Release lever .....	1
2	500 0304.6	Spring .....	1	32	500 1072.7	Pin .....	1
3	500 0301.1	Fixing blade .....	1	33*	500 1023.9	Snap ring .....	2
4	500 0302.0	Blade spacer .....	1	34	500 1015.8	Release valve stem .....	1
5	500 0303.8	Front blade .....	1	35*	500 1014.0	O-ring .....	1
6	500 0228.7	Stud .....	4	36	500 1021.2	Spring .....	1
7	500 0226.0	Nut .....	8	37	500 1037.9	7/32" Ball .....	1
8	500 0332.1	Pivot .....	2	38	500 1038.7	Spring .....	1
9	500 0331.3	Circlip .....	2	39*	500 1039.5	O-ring .....	1
10	500 0227.9	Washer .....	8	40*	500 1040.9	Back-up ring .....	1
11	500 0336.4	Moving blade .....	1	41	500 1041.7	Valve screw .....	1
12	500 0487.5	Fixing screw .....	1	42*	500 1058.1	O-ring .....	1
13	500 0335.6	Spindle hub .....	1	43*	500 1054.9	O-ring .....	1
14	500 0316.0	Spring .....	1	44	500 1062.0	Relief valve .....	1
15	500 0488.3	Output piston .....	1	45*	500 1052.2	Copper gasket .....	1
16*	500 0489.1	Back-up ring .....	1	46*	500 1049.2	Spring .....	1
17*	500 0490.5	O-ring .....	1	47*	500 1050.6	3/16" Ball .....	1
18	500 1036.0	Main body .....	1	48*	500 1053.0	Suction valve screw assy .....	1
19	500 0579.0	7/32" ball .....	1	49*	500 0330.5	Oil screen .....	1
20	500 0492.1	Spring .....	1	50*	500 0334.8	Screen holder .....	1
21	500 0491.3	Valve screw .....	1	51	500 1055.7	Oil reservoir .....	1
22	500 1016.6	Spring .....	1	52	500 1056.5	Filler cap .....	1
23*	500 1035.2	Oil ring .....	1	53	500 1065.4	Body handle head .....	1
24*	500 1034.4	Back-up ring .....	1	54	500 1066.2	Spring pin .....	1
25*	500 1033.6	Oil seal .....	1	55	500 1060.3	Body handle .....	1
26	500 1028.0	Pump piston .....	1	56	500 1061.1	Body handle grip .....	1
27	500 1043.3	Pin .....	2	57	500 1068.9	Holding band .....	1
28*	500 1044.1	Snap ring .....	4	58	501 0868.9	Spring pin .....	2
29	500 1045.0	Pump handle .....	1	59	501 0869.7	Screw .....	1
30	500 1048.4	Pump handle grip .....	1	60	501 0870.0	Ring cover .....	1
				*	500 1078.6	Seal kit (includes items marked with asterisk)	
					501 0620.1	Stud kit (includes items 6,7,10)	
					501 0621.0	Pivot kit (includes items 8,9)	



USA	(800) 435-0786	Fax:	(800) 451-2632
	(815) 397-7070	Fax:	(815) 397-1865
Canada	(800) 435-0786	Fax:	(800) 524-2853
International	+1 (815) 397-7070	Fax:	+1 (815) 397-9247

4455 Boeing Drive, Rockford, IL 61109-2988 • USA • 815-397-7070  
An ISO 9001 Company • Greenlee Textron is a subsidiary of Textron Inc.

[www.greenlee.com](http://www.greenlee.com)