

INSTRUCTION MANUAL

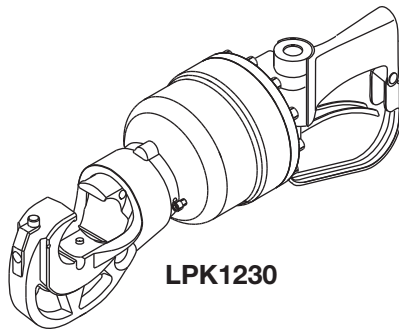

LPK1230

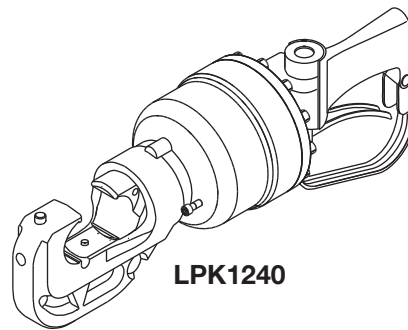

LPK1240

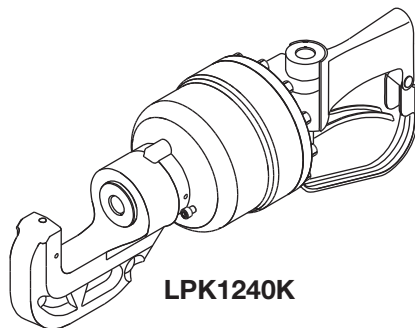

LPK1240K

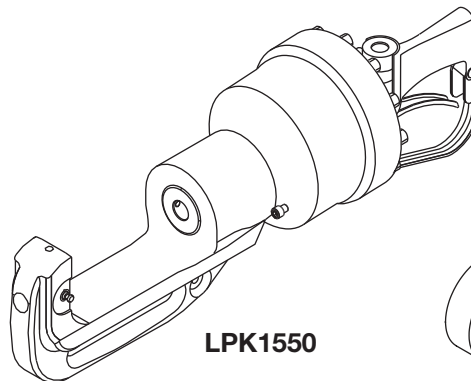

LPK1550

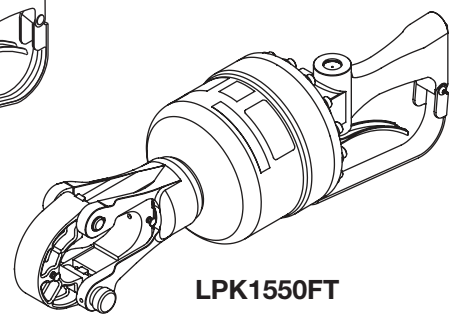

LPK1550FT

Hydraulic Crimping Tools



Read and understand all of the instructions and safety information in this manual before operating or servicing this tool.

Register this product at www.greenlee.com

Table of Contents

Description	2
Safety	2
Purpose of this Manual	2
Other Publications	2
Important Safety Information	3-5
Identification	6
Specifications	7-8
Tool Setup	9
Hoses and Fittings	10
Hose Connections	10
Typical Setup	10
Operation	11
LPK1550 Die Installation	12-14
LPK1550FT Die Installation	15
Maintenance	16
Periodic Pressure Relief Valve Check	16
Troubleshooting	17
Illustrations and Parts Lists	18-27

Description

Greenlee Hydraulic Crimping Tools are intended to crimp connectors onto electrical cable. All of these crimping tools can be adapted for use with either open-center or closed-center hydraulic systems.

The crimping tools and removable dies* they accept are as follows:

LPK1230, LPK1240, and LPK1240K 12-ton Hydraulic Crimping Tools

30 mm (1.18") Jaw Opening

LPK1230: Industry Standard 12-ton Type "U" Dies

42 mm (1.65") Jaw Opening

LPK1240: Industry Standard 12-ton Type "U" Dies

LPK1240K: Kearney PH2 and WH2 Dies

LPK1550 15-ton Hydraulic Crimping Tool

Jaw Opening is dependent on Die Set

Kearney PH14 Dies

Kearney PH2 Dies (requires 48824 Die Holder Kit)*

Thomas & Betts TBM 15 Dies
(requires 48788 Die Holder Kit)*

Burndy™ Y46 Type "P" Dies
(requires 48820 Die Holder Kit)*

Industry Standard 12-ton Type "U" Dies
(requires 48802 Die Holder Kit)*

LPK1550FT 15-ton Hydraulic Crimping Tool

50.8 mm (2.00") Jaw Opening

Ilscs ILD-P Dies

Burndy™ "P" Dies

Industry Standard 12-ton Type "U" Dies
(requires 52060610 "U" Die Adapter Kit)*

* The dies and die holder kits are purchased separately.
These tools are protected by U.S. Patent No. 5,778,755.

Safety

Safety is essential in the use and maintenance of Greenlee tools and equipment. This instruction manual and any markings on the tool provide information for avoiding hazards and unsafe practices related to the use of this tool. Observe all of the safety information provided.

Purpose of this Manual

This manual is intended to familiarize all personnel with the safe operation and maintenance procedures for the following Greenlee tools:

LPK1230 (49340)	Serial Code FYB
LPK1240 (49345)	Serial Code FYD
LPK1240K (49350)	Serial Code FYE
LPK1550 (49355)	Serial Code FYF
LPK1550FT (00490)	Serial Code GPC

Keep this manual available to all personnel.

Replacement manuals are available upon request at no charge at www.greenlee.com.

Other Publications

Tool Owners/Users

SAE Standard J1273 (Hose and Hose Assemblies):
Publication 99930323

Greenlee Authorized Service Centers

Service Manuals:

LPK1230:	Publication 99932253
LPK1240:	Publication 99932261
LPK1240K:	Publication 99932270
LPK1550:	Publication 99932288
LPK1550FT:	Publication 52059642

All specifications are nominal and may change as design improvements occur. Greenlee Tools, Inc. shall not be liable for damages resulting from misapplication or misuse of its products. Blackburn is a registered trademark of Thomas and Betts Corporation. Burndy is a trademark of Framatome Connectors International.

IMPORTANT SAFETY INFORMATION



SAFETY ALERT SYMBOL

This symbol is used to call your attention to hazards or unsafe practices which could result in an injury or property damage. The signal word, defined below, indicates the severity of the hazard. The message after the signal word provides information for preventing or avoiding the hazard.

⚠ DANGER

Immediate hazards which, if not avoided, WILL result in severe injury or death.

⚠ WARNING

Hazards which, if not avoided, COULD result in severe injury or death.

⚠ CAUTION

Hazards or unsafe practices which, if not avoided, MAY result in injury or property damage.



⚠ WARNING

Electric shock hazard:
This tool is not insulated. When using this unit near energized electrical lines, use only certified non-conductive hoses and proper personal protective equipment.
Failure to observe this warning could result in severe injury or death.



⚠ WARNING

Skin injection hazard:

- Do not use hands to check for leaks.
- Do not hold hose or couplers while the hydraulic system is pressurized.
- Depressurize the hydraulic system before servicing.

Oil under pressure easily punctures skin, causing serious injury, gangrene, or death. If you are injured by escaping oil, seek medical attention immediately.



⚠ WARNING

Read and understand all of the instructions and safety information in this manual before operating or servicing this tool.
Failure to observe this warning could result in severe injury or death.

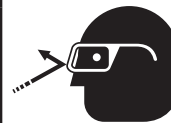

⚠ WARNING

Wear eye protection when operating or servicing this tool.
Failure to wear eye protection could result in serious eye injury from flying debris or hydraulic oil.



⚠ WARNING

Wear hearing protection when using this tool.
Long-term exposure to high noise levels could result in hearing damage.

KEEP THIS MANUAL

IMPORTANT SAFETY INFORMATION

	<p align="center">⚠ WARNING</p> <p>The hydraulic cylinder may be hot during and after operation. Hot surfaces can cause serious burns.</p>
---	---

<p align="center">⚠ WARNING</p> <p>Do not disconnect tool, hoses, or fittings while the power source is running or if the hydraulic fluid is hot. Hot hydraulic fluid can cause serious burns.</p>

	<p align="center">⚠ WARNING</p> <p>Keep hands away from the crimping tool head when crimping. Failure to observe this warning could result in severe injury or death.</p>
---	--

<p align="center">⚠ WARNING</p> <p>Do not reverse hydraulic flow. Operation with hydraulic flow reversed can cause tool malfunction. Connect the pressure (supply) hose and tank (return) hose to the proper tool ports. Failure to observe this warning could result in severe injury or death.</p>

<p align="center">⚠ WARNING</p> <p>An incomplete crimp can cause a fire.</p> <ul style="list-style-type: none"> • Use proper die, connector, and cable combinations. Improper combinations can result in an incomplete crimp. • The relief valve sounds to indicate a completed crimp. If you do not hear the sound of the relief valve, the crimp is not complete. <p>Failure to observe these warnings could result in severe injury or death.</p>

<p align="center">⚠ WARNING</p> <p>Do not change accessories, inspect, adjust, or clean tool when it is connected to a power source. Accidental start-up can result in serious injury. Failure to observe this warning could result in severe injury or death.</p>

<p align="center">⚠ WARNING</p> <p>Do not exceed the following hydraulic power source maximums:</p> <ul style="list-style-type: none"> • Hydraulic flow: 34.1 l/min (9 gpm). • Pressure relief setting: 172 bar (2500 psi). • Back pressure: 13.8 bar (200 psi) <p>Failure to observe this warning could result in severe injury or death.</p>
--

<p align="center">⚠ WARNING</p> <ul style="list-style-type: none"> • Inspect tool before use. Replace any worn or damaged parts. A damaged or improperly assembled tool can break and strike nearby personnel. • Inspect the hydraulic hoses and couplings every operating day. Repair or replace if leakage, cracking, wear, or damage is evident. Damaged hoses or couplings can fail, resulting in injury or property damage. • Use this tool for manufacturer's intended use only. Use other than that which is described in this manual could result in injury or property damage. <p>Failure to observe these warnings could result in severe injury or death.</p>
--

IMPORTANT SAFETY INFORMATION

CAUTION

- Do not operate the tool without a set of dies in place. Damage to the ram or crimping tool head can result.
- Maintain proper footing to prevent loss of balance in case of unexpected movement of the crimping tool.
- Do not perform any service or maintenance other than as described in this manual. Injury or damage to the tool may result.

Failure to observe these precautions may result in injury and property damage.

CAUTION

Hydraulic oil can cause skin irritation.

- Handle the tool and hoses with care to prevent skin contact with hydraulic oil.
- In case of accidental skin contact with hydraulic oil, wash the affected area immediately to remove the oil.

Failure to observe these precautions may result in injury.

IMPORTANT

Procedure for connecting or disconnecting hydraulic hoses, fittings, or components:

1. Move the flow lever on the hydraulic power source to the OFF position.
2. Stop the hydraulic power source.
3. Follow the sequence under “Hose Connections” to prevent pressure buildup. In case some pressure has built up, loosen hoses, fittings, or components slowly.

IMPORTANT

Emergency stop procedure:

1. Release the trigger.
2. Shut off the hydraulic power source.

Note: Keep all decals clean and legible, and replace when necessary.

Identification

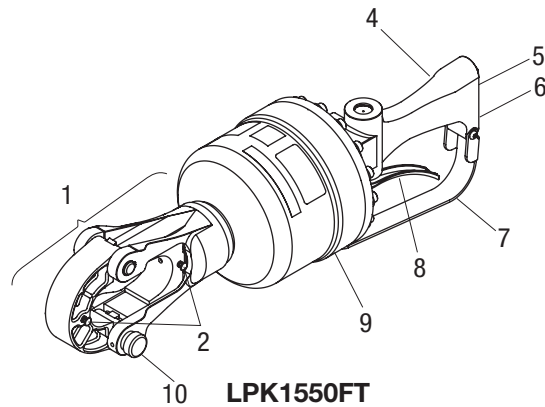
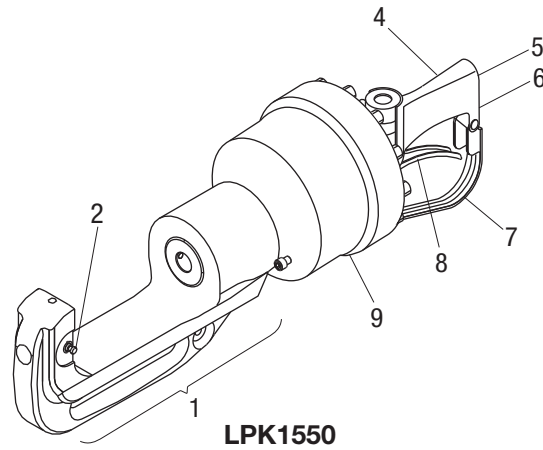
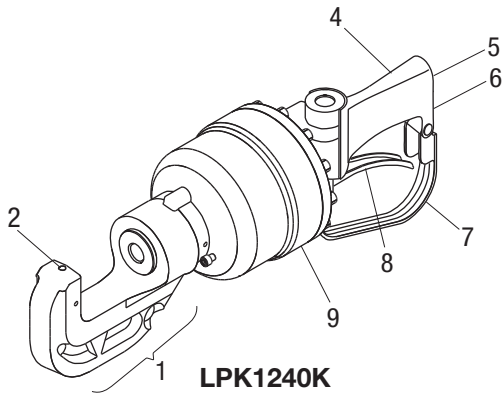
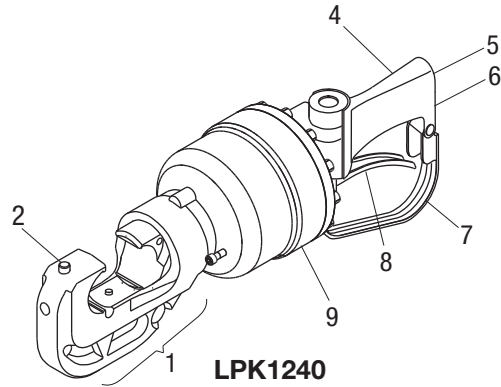
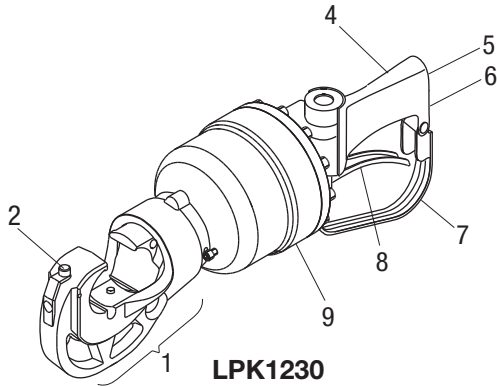

- | | |
|---------------------------------------|--------------------------------------|
| 1. Crimping Head | 6. Pressure Port (closer to trigger) |
| 2. Crimping Head Release Mechanism | 7. Trigger Strap |
| 3. Dies (not included) | 8. Trigger |
| 4. Handle | 9. Cylinder |
| 5. Return Port (farther from trigger) | 10. Pull Pin (LPK1550FT only) |

Specifications

Crimping Tool—All Models

Type of Hydraulic System: Open-center or closed-center

Hydraulic Ports:

Pressure (supply): 3/4-16 UNF SAE O-ring Boss

Tank (return): 3/4-16 UNF SAE O-ring Boss

Noise Levels

L_{WA} (Sound Power Level): 55.5 dB

L_{pCpeak} (Peak Emission Sound Pressure Level): 68.8 dB

Vibration: 3.15 ms²

LPK1230 Crimping Tool

Stroke (with dies): 30 mm (1.19")

Crimping Force @ 103 bar (1500 psi): 106.7 kN (24,000 lb)

Mass/Weight: 8.4 kg (18.5 lb)

Length: 490 mm (19.3")

Width: 140 mm (5.5")

LPK1240 Crimping Tool

Stroke (with dies): 42 mm (1.65")

Crimping Force @ 103 bar (1500 psi): 106.7 kN (24,000 lb)

Mass/Weight: 8.9 kg (19.7 lb)

Length: 516 mm (20.3")

Width: 140 mm (5.5")

LPK1240K Crimping Tool

Stroke (with dies): 41 mm (1.62")

Crimping Force @ 103 bar (1500 psi): 106.7 kN (24,000 lb)

Mass/Weight: 8.8 kg (19.5 lb)

Length: 516 mm (20.3")

Width: 140 mm (5.5")

LPK1550 Crimping Tool

Stroke (without dies): 58 mm (2.28")

Crimping Force @ 103 bar (1500 psi): 133 kN (30,000 lb)

Mass/Weight: 13.0 kg (28.6 lb)

Length: 605 mm (23.8")

Width: 165 mm (6.5")

LPK1550FT Crimping Tool

Stroke (without dies): 50.8 mm (2.00")

Crimping Force @ 103 bar (1500 psi): 133 kN (30,000 lb)

Mass/Weight: 11.1 kg (24.5 lb)

Length: 602 mm (23.7")

Width: 165 mm (6.5")

Specifications (cont'd)

Hydraulic Power Source

⚠ WARNING

Do not exceed the following hydraulic power source maximums:

- Hydraulic flow: 34.1 l/min (9 gpm).
- Pressure relief setting: 172 bar (2500 psi).
- Back pressure: 13.8 bar (200 psi)

Failure to observe this warning could result in severe injury or death.

Hydraulic Schematic

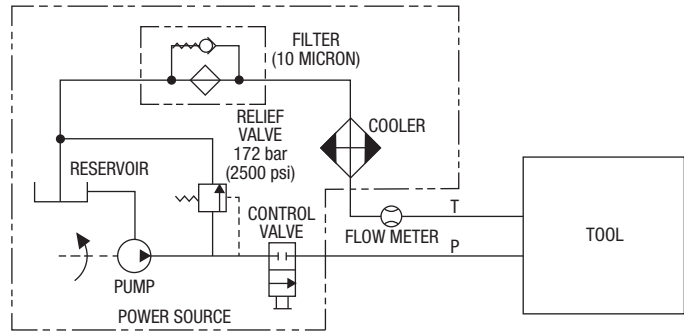

Type of Hydraulic System: Open-center or closed-center

Flow:

- Minimum: 11.4 l/min (3 gpm)
- Recommended: 22.7 l/min (6 gpm)
- Maximum: 34.1 l/min (9 gpm)

Pressure Relief Setting:

- Minimum: 103 bar (1500 psi)
- Maximum: 172 bar (2500 psi)

Filtration: 10 micron (nominal)

Back Pressure (maximum*): 13.8 bar (200 psi)

* 13.8 bar (200 psi) is the maximum agreed standard back pressure for the HTMA (Hydraulic Tool Manufacturers Association). Greenlee tools will operate satisfactorily at this standard.

1. Maximum hydraulic fluid temperature must not exceed 60 °C (140 °F). A sufficient oil cooling capacity is needed to limit the hydraulic fluid temperature.
2. Hydraulic flow must not exceed 34.1 l/min (9 gpm). Install a flow meter in the return line to measure the rate of hydraulic flow before using the tool.
3. Pressure relief valve setting must not exceed 172 bar (2500 psi) at your tool's maximum flow. Locate the pressure relief valve in the supply circuit to limit excessive hydraulic pressure to the tool.

Recommended Hydraulic Fluids

Use any nondetergent, petroleum-based hydraulic fluid which meets the following specifications or HTMA specifications.

S.U.S. @:

- 38 °C (100 °F): 140 to 225
- 99 °C (210 °F): 40 minimum

Flash Point: 170 °C (340 °F) minimum

Pour Point: -34 °C (-30 °F) minimum

Tool Setup

This tool can be used on either open-center or closed-center hydraulic systems.

Open-Center Setting

1. With the ram retracted, disconnect the crimping tool from the hydraulic power source.
2. Loosen the two seal nuts. Back each seal nut out to the end of the screw.
3. Turn the screws clockwise—evenly, alternating every one to two turns—until they contact the piston and feel snug.
4. Back the screws out—evenly, alternating every one to two turns—exactly four complete turns.
5. Hold the screws in place with an Allen wrench and tighten the seal nuts against the cover. Torque the seal nuts to 6.78 newton-meters (5 ft-lb).

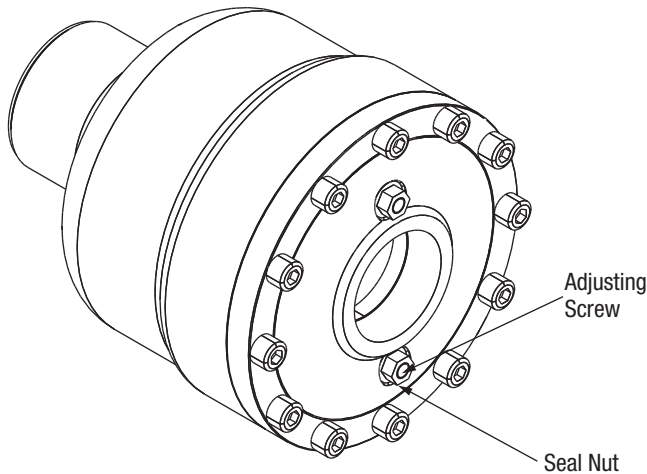

Closed-Center Setting

1. Disconnect the crimping tool from the hydraulic power source.
2. Loosen the two seal nuts.
3. Turn the screws counterclockwise—evenly, alternating every one to two turns—until they contact the stops.
4. Hold the screws in place with an Allen wrench and tighten the seal nuts against the cover. Torque the seal nuts to 6.78 newton-meters (5 ft-lb).

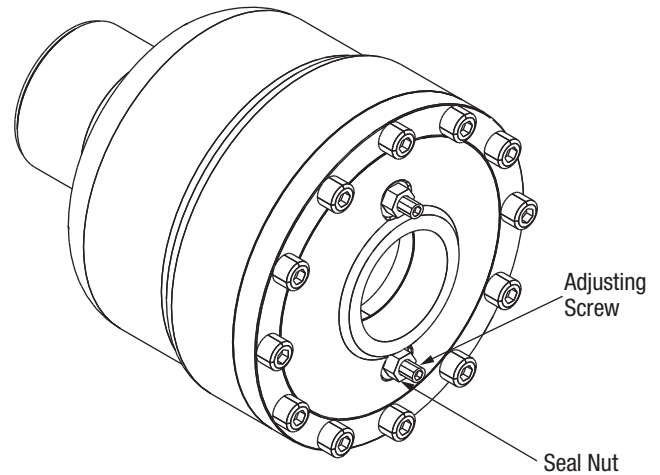

Installing Dies

1. Clean the die seat area.
2. Install the proper size and type of crimping dies.
Note: For LPK1550 and LPK1550FT only, refer to "LPK1550 Die Installation" or "LPK1550FT Die Installation."

Hoses and Fittings

Installation and Maintenance

Refer to publication 99930323, SAE J1273 (Hose and Hose Assemblies).

Replacement

Refer to a Greenlee catalog or publication 99910322, Low Pressure Quick Couplers, Adapters and Hoses.

⚠ WARNING

Do not disconnect tool, hoses, or fittings while the power source is running or if the hydraulic fluid is hot. Hot hydraulic fluid can cause serious burns.

Hose Connections

Tool Port Identification

Three methods are used to identify the pressure and return ports of Greenlee tools. Match the markings on your tool to this table.

Pressure Port	Return Port
P	T
or	
In	Out
or	
3/4-16 O-ring Boss	

Connecting Hoses

1. Move the flow control lever on the hydraulic power source to the OFF position.
2. Stop the hydraulic power source.
3. Connect the return hose to the return port on the power source, and then to the return port on the tool.
4. Connect the pressure hose to the pressure port on the tool, and then to the pressure port on the power source.

Disconnecting Hoses

1. Move the flow control lever on the hydraulic power source to the OFF position.
2. Stop the hydraulic power source.
3. Disconnect the pressure hose from the power source, and then from the tool.
4. Disconnect the return hose from the tool, and then from the power source.

Typical Setup

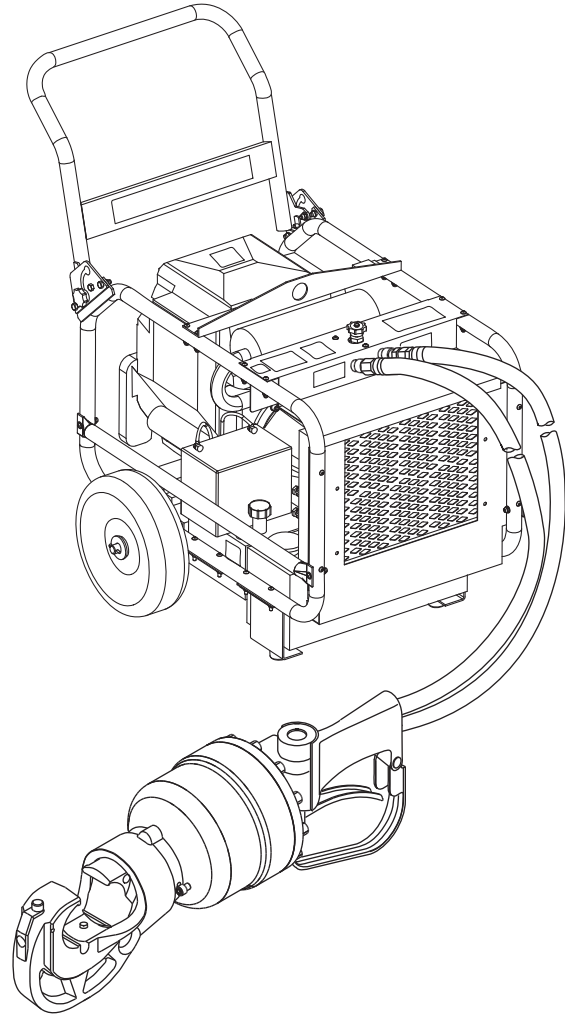

Operation

	⚠ WARNING
	<p>Electric shock hazard:</p> <p>This tool is not insulated. When using this unit near energized electrical lines, use only certified non-conductive hoses and proper personal protective equipment.</p> <p>Failure to observe this warning could result in severe injury or death.</p>

⚠ WARNING
<p>An incomplete crimp can cause a fire.</p> <ul style="list-style-type: none"> • Use proper die, connector, and cable combinations. Improper combinations can result in an incomplete crimp. • The relief valve sounds to indicate a completed crimp. If you do not hear the sound of the relief valve, the crimp is not complete. <p>Failure to observe these warnings could result in severe injury or death.</p>

	⚠ WARNING
	<p>Skin injection hazard:</p> <ul style="list-style-type: none"> • Do not use hands to check for leaks. • Do not hold hose or couplers while the hydraulic system is pressurized. • Depressurize the hydraulic system before servicing. <p>Oil under pressure easily punctures skin, causing serious injury, gangrene, or death. If you are injured by escaping oil, seek medical attention immediately.</p>

1. Refer to the connector manufacturer's instructions for cable preparation and the crimping procedure.
2. Center the connector between the dies or nibs.
3. Press the trigger to advance the dies or nibs.
 - Press the trigger down completely for fast advance.
 - Press the trigger down partially for slow advance.
4. Continue crimping until the pressure relief valve activates.

Note: Pressure relief is indicated by a change in the sound from the crimping tool and a sudden stiffening of the hydraulic hoses.
5. After achieving pressure relief, release the trigger. The dies retract.
6. Complete the number of crimps specified by the connector manufacturer.
7. When the tool is not in use, stop the power source to reduce heat and wear on tool components.

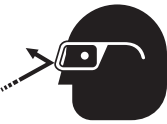
	⚠ WARNING
	<p>Wear eye protection when operating or servicing this tool.</p> <p>Failure to wear eye protection could result in serious eye injury from flying debris or hydraulic oil.</p>

	⚠ WARNING
	<p>Keep hands away from the crimping tool head when crimping.</p> <p>Failure to observe this warning could result in severe injury or death.</p>

LPK1550 Die Installation

Kearney PH14 Dies

Note: No die holder assemblies are needed. Dies fit directly into tool.

1. Select proper die set for fitting to be crimped.
Note: Do not use non-butting dies (crimps controlled by tonnage) in this tool, as damage could occur to connectors and/or conductors.
2. Install upper die in hole in top of "C" head. Detent screw will snap into groove of die.
3. Install lower die in hole in end of piston. Detent screw will snap into groove of die.

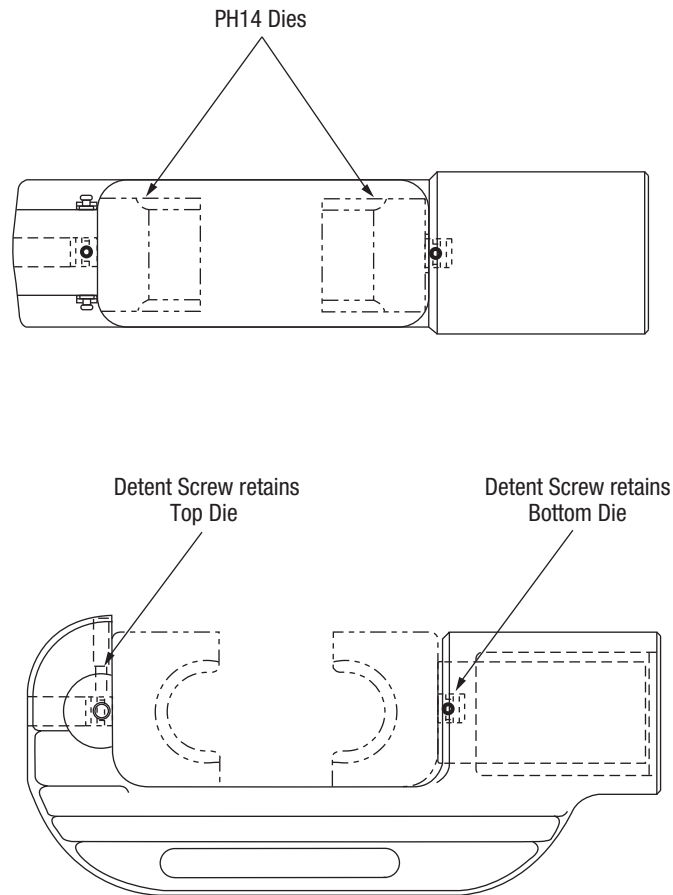

Kearney PH2 Dies and 48824 Die Holder Kit

1. Install 48823G PH2 die spacer assembly into hole in top of "C" head. Detent screw will snap into groove of die spacer.
2. Install upper 48825 die holder assembly into hole in die spacer assembly. Lock in place with die spacer retaining screw.
3. Install lower 48825 die holder assembly in hole in end of piston. Detent screw will snap into groove of die holder.

4. Select proper die set for fitting to be crimped.
Note: Do not use non-butting dies (crimps controlled by tonnage) in this tool, as damage could occur to connectors and/or conductors.
5. Slide die into place in top die holder tight against shoulder. Detent screw snaps into groove of die. Lock in place with top die retaining cap screw. Repeat for other die.

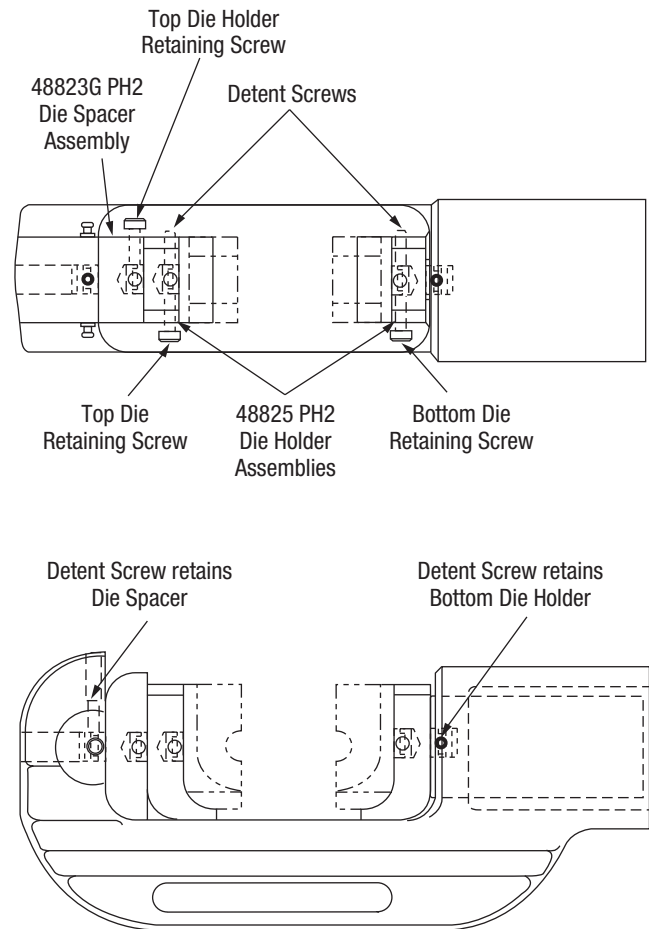

48824 Die Holder Kit for PH2 Dies contains one 48823G and two 48825 Die Holders

LPK1550 Die Installation (cont'd)

Thomas & Betts TBM 15 Dies and 48788 Die Holder Kit

1. Install the upper 48789 die holder assembly in hole in top of "C" head. Detent screw will snap into groove of die holder.
2. Install lower 48789 die holder assembly in hole in end of piston. Detent screw will snap into groove of die holder.
3. Select proper die set for the connector to be crimped.
4. Slide top die into place in die holder while depressing die retainer button. Release die button while it snaps into place, locking die into position. Repeat for other die.

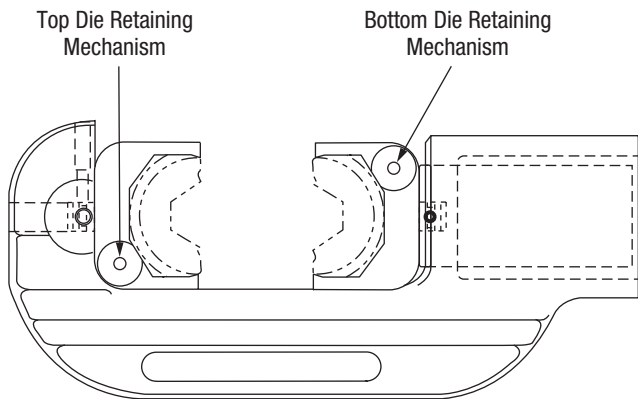
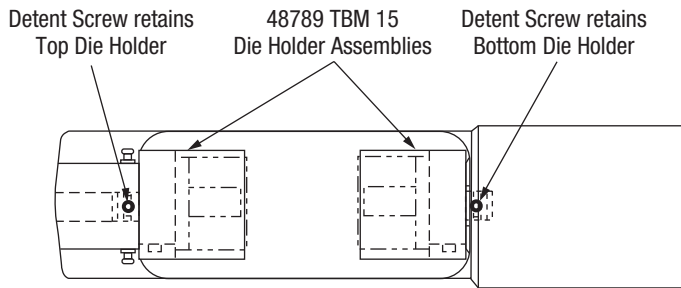

48788 Die Holder Kit contains two 48789 Die Holders

Burndy Y46 Type P Dies and 48820 Die Holder Kit

1. Install the upper 48822 die holder assembly in hole in top of "C" head. Detent screw will snap into groove of die holder.
2. Install lower 48821 die holder assembly in hole in end of piston. Detent screw will snap into groove of die holder.
3. Select proper die set for the connector to be crimped.
4. Slide top die into place in die holder while simultaneously squeezing both retainer buttons. Release buttons and allow them to snap into place. Repeat for other die.

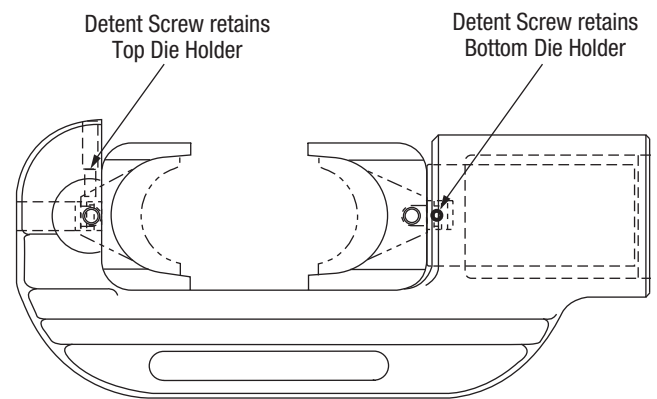
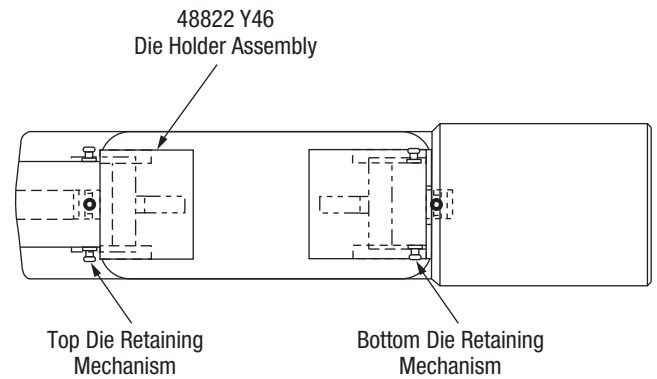

48820 Die Holder Kit contains one 48822 Upper Die Holder and one 48821 Lower Die Holder

LPK1550 Die Installation (cont'd)

Industry Standard 12-ton Type "U" Dies and 48802 Die Holder Kit

1. Install the upper 48803G die holder assembly in hole in top of "C" head. Detent screw will snap into groove of die holder.
2. Install lower 48803G die holder assembly in hole in end of piston. Detent screw will snap into groove of die holder.
3. Select proper die set for the connector to be crimped.
4. Slide die into place in die holder while depressing die retainer button. Release die button while it snaps into place, locking die into position. Repeat for other die.

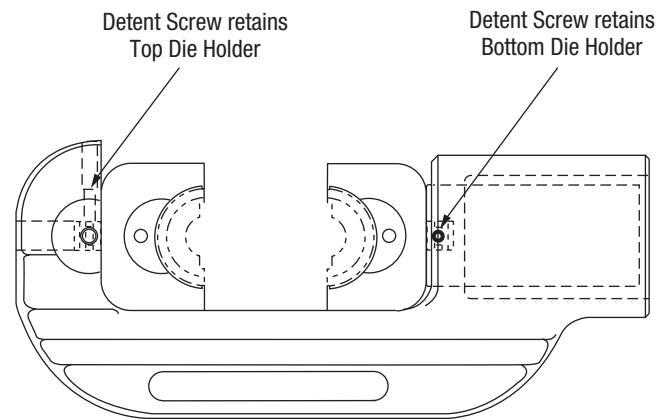
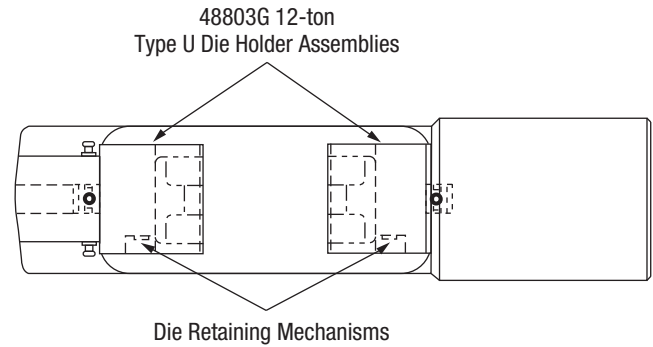

48802 Die Holder Kit for 12-ton Type "U" Dies contains two 48803G Die Holders

LPK1550FT Die Installation

Procedure for Using “P” Style Dies

1. No die holder assemblies are needed. Dies fit directly into tool.
2. Select proper die set for connector to be crimped.
3. Slide top die into place in die holder while simultaneously squeezing retainer button. Release button and allow die to snap into place. Repeat operation for other die entry.

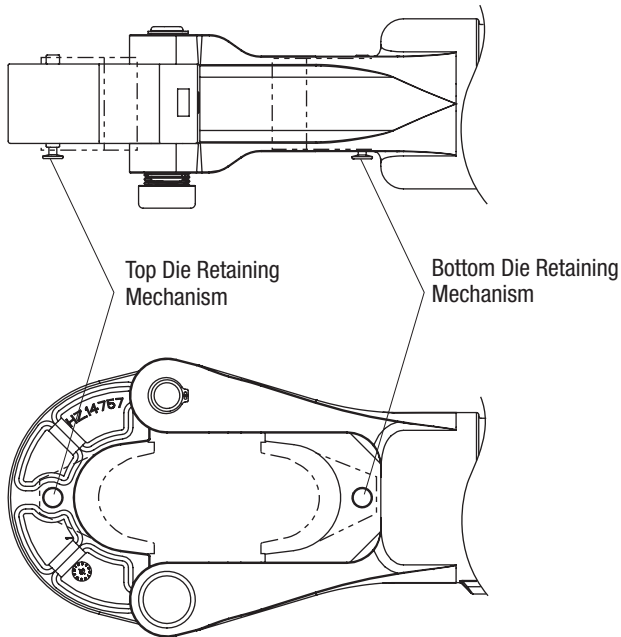

Procedure for Using 12-ton “U” Style Dies with UA15T Die Adapter Set

1. Slide a die adapter assembly into the flip-top head while depressing the die retainer button. Release the retainer button while the adapter snaps into place. The die adapter should be locked in position.
2. Repeat Step 1 to install the other die adapter into the ram end.
3. Select the proper “U” die set for the connector to be crimped.
4. Slide the “U” die into the die adapter while depressing the die retainer button. Release the die button while it snaps into place, locking the die into position.
5. Repeat Step 4 with other “U” die.

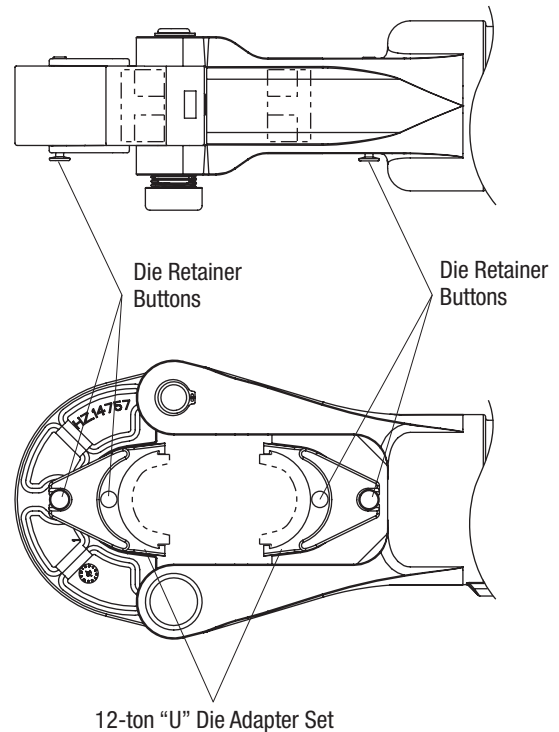

Maintenance

	⚠ WARNING
	<p>Skin injection hazard:</p> <ul style="list-style-type: none"> • Do not use hands to check for leaks. • Do not hold hose or couplers while the hydraulic system is pressurized. • Depressurize the hydraulic system before servicing. <p>Oil under pressure easily punctures skin, causing serious injury, gangrene, or death. If you are injured by escaping oil, seek medical attention immediately.</p>

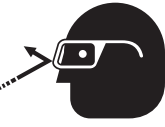
	⚠ WARNING
	<p>Wear eye protection when operating or servicing this tool.</p> <p>Failure to wear eye protection could result in serious eye injury from flying debris or hydraulic oil.</p>

Periodic Pressure Relief Valve Check

Test the crimping tool periodically to ensure that the pressure relief valve activates at the proper pressure.

1. Test the crimping tool with either a Greenlee load cell or with an in-line pressure gauge.
 - Purchase a Greenlee Load Cell, catalog number 35887. Refer to the instructions supplied with the load cell.
 - Install an in-line pressure gauge on the input side of the tool. With dies in place, perform a test crimp.
2. Pressure relief should occur at 103 to 107 bar (1500 to 1550 psi).
3. If pressure relief occurs outside of the specified range, send the crimping tool to a Greenlee Authorized Service Center.

Notes:

- (1) *Keep all decals clean and legible. Replace decals when necessary.*
- (2) *When disposing of any components (hydraulic hoses, hydraulic fluid, worn parts, etc.), do so in accordance with federal, state and local laws or ordinances.*

Daily

1. Thoroughly wipe all tool surfaces clean. Remove any oxide inhibitor, connector contact compound, and grit from the die seat areas, dies and die holders.
2. Inspect the hydraulic hoses and fittings for signs of leaks, cracks, wear or damage. Replace if necessary.
3. Install dust caps over the hydraulic ports when the tool is disconnected.

Monthly

1. Perform a thorough inspection of the hydraulic hoses and fittings as described in publication 99930323, SAE J1273 (Hose and Hose Assemblies).
2. Apply a light oil to all moving parts.

Quarterly or Every 500 Crimps

Perform the "Periodic Pressure Relief Valve Check."

Annually

If required by your organization's regulations, send the tool to a Greenlee Authorized Service Center.

Troubleshooting

Before troubleshooting, determine whether the problem is in the tool, the hoses, or the power source. Substitute a tool, hoses, or power source known to be in good working order to eliminate the item that is not operating.

If the problem is in the tool, see the troubleshooting table in this manual. If the problem is in the power source, see the troubleshooting section of the power source instruction manual.

Problem	Probable Cause	Probable Remedy
Tool does not operate.	Improper power source.	Verify that the power source meets the specifications. Refer to the “Specifications” section.
	Hydraulic fluid level low.	Check the fluid level. Check system for leaks.
	Incorrect hydraulic fluid viscosity.	Use hydraulic fluid with the correct viscosity. Refer to the “Specifications” section.
Tool operates slowly or erratically.	Hydraulic fluid cold.	Allow fluid to warm to the operating temperature. Actuate the tool intermittently to reduce the warming time.
	Power source not adjusted correctly.	Refer to the power source operator’s manual. Set the flow and pressure to correspond with the tool.
	Hydraulic fluid level low.	Check the fluid level. Check system for leaks.
	Air in the hydraulic system.	Refer to the power source manufacturer’s instructions for removing air from the system.
	Incorrect hydraulic fluid viscosity.	Use hydraulic fluid with the correct viscosity. Refer to the “Specifications” section.
Tool feels hot.	Hydraulic fluid level low.	Check the fluid level. Check for leaks.
	Incorrect hydraulic fluid viscosity.	Use hydraulic fluid with the correct viscosity. Refer to the “Specifications” section.
	Hydraulic fluid dirty.	Refer to the power source owner’s manual for procedure to replace hydraulic oil and filter.
Tool operates backward.	Hose connections at tool are reversed.	Depressurize the hydraulic system. Switch the hose connections.
Crimping tool does not achieve pressure relief.	Improper power source.	Verify that the power source meets the specifications. Refer to the “Specifications” section.
Dies do not retract.	Dies caught on crimped connector.	Twist crimping tool from side to side to free it from the connector.
	Excessive system back pressure.	Troubleshoot the hydraulic system.

**Illustration—
LPK1230**

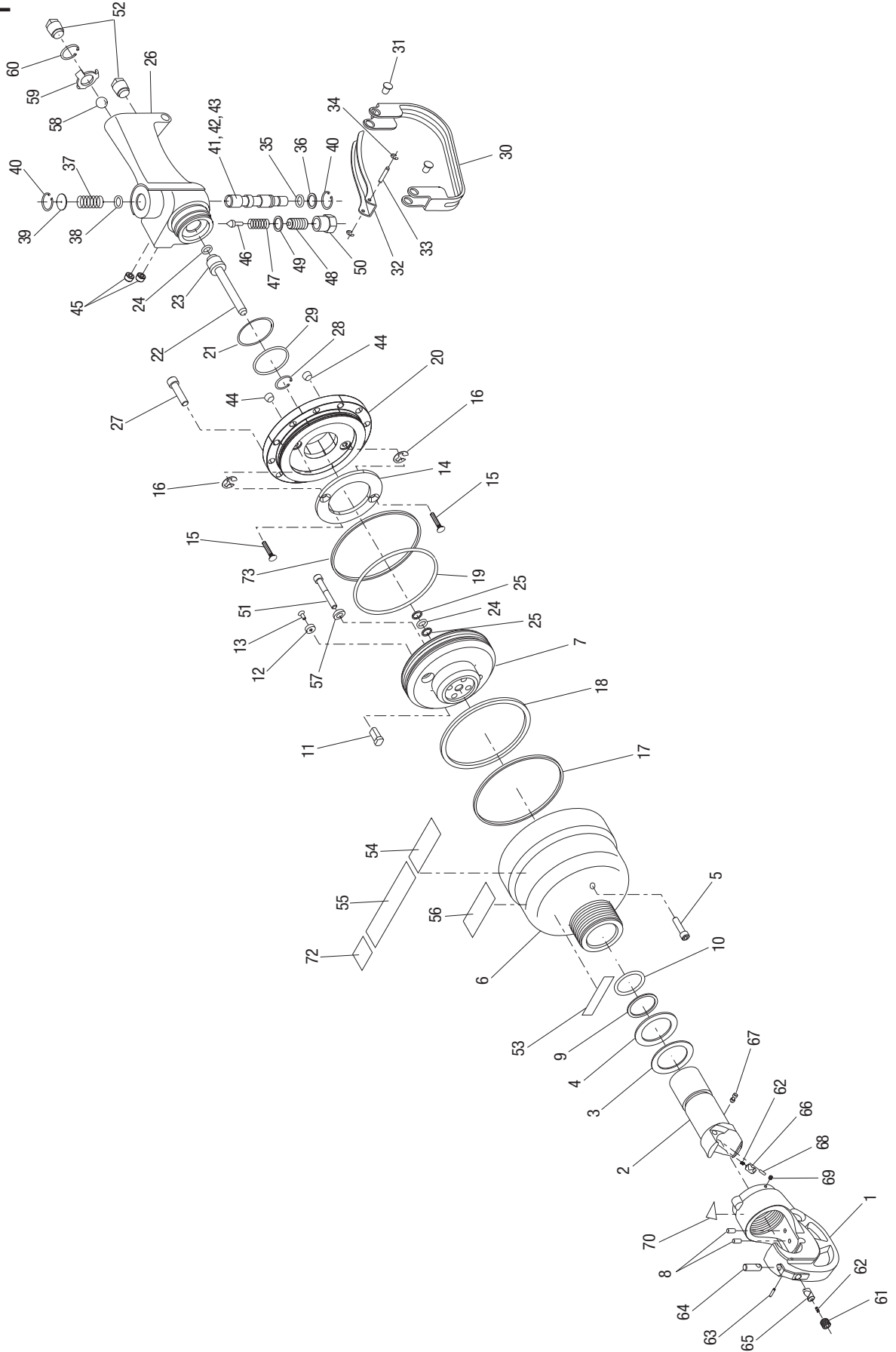

Parts List—LPK1230

Key	UPC No. 78-3310-	Part No.	Description	Qty	Key	UPC No. 78-3310-	Part No.	Description	Qty
1	05372	50053728	C-head unit (includes items 8, 61–65, 69, 70).....	1	45			Plug, pipe, 1/8" NPTF.....	2
2	49342	50493426	Ram.....	1	46	30146	50301462	Pin, valve, .305 x .870".....	1
3*			Washer, ram.....	1	47	40692	50406921	Spring, unloading valve.....	1
4*			Wiper, ram.....	1	48	48261	50482610	Screw, set, 1/2–20, adjusting.....	1
5			Screw, cap, 1/4–20 x .87", socket head.....	1	49*			Washer, flat, .514 x .030, copper.....	1
6	49344	52026772	Cylinder (includes items 53–56, 71, 72).....	1	50	48260G	50482602	Cap, relief valve.....	1
7	48733	50487337	Piston.....	1	51			Screw, cap, 1/4–20 x 1.625, socket.....	4
8*			Pin, groove (6 mm x 12 mm).....	2	52	41432	50414323	Plug, port.....	2
9*			Backup ring, 1.375 x 1.62 x .121".....	1	53	49947	50499475	Decal.....	1
10*			O-ring, 1.375 x 1.62 x .125".....	1	54	48734	50487345	Decal, OC/CC setting.....	1
11	43546	50435469	Spool, shuttle.....	2	55	49946	50499467	Decal, warning.....	1
12	43547	50435477	Washer, shuttle.....	2	56	41547	50415471	Decal, Greenlee.....	1
13			Screw, cap, #6–32 x .375", flat head socket.....	2	57	54913	90549139	Washer, conical, .55 x .25 x .05.....	4
14	48727	50487272	Ring, shuttle stop.....	1	58	41873	50418730	Ball, steel, .5".....	1
15	48728	50487280	Screw, stop ring.....	2	59	49234	50492349	Stop, ball.....	1
16*			Retaining ring.....	2	60	41600	50416003	Retaining ring, .687.....	1
17*			Backup ring, 4.312 x 4.500 x .125.....	1	61	55060	90550609	Screw, M12-1.75 x 12 mm set.....	1
18*			Seal unit.....	1	62	03821	50038214	Spring.....	2
19*			O-ring.....	1	63	55063G	90550633	Pin, grooved, 3 mm.....	1
20	45659	50456598	Cover, cylinder.....	1	64	05317	50053175	Button, die release.....	1
21	48737	50487370	Shim, handle.....	6 (max)	65	05319	50053191	Pin, die release.....	1
22	43554	50435540	Tube.....	1	66	05316	50053167	Pin, die release.....	1
23	42685	50426851	Carrier, seal.....	1	67	05318	50053183	Button, die release.....	1
24*			O-ring, .375 x .500 x .062"–70.....	2	68	55064	90550641	Rollpin, 3 mm x 10 mm.....	1
25*			Backup ring, .382 x .486 x .045".....	2	69	55061	90550617	Screw, M5-.8 x 5 mm set.....	1
26	48736	50487361	Handle.....	1	70	06214	50062140	Decal, pinch warning.....	1
27			Screw, cap, 5/16–18 x 1.25", socket head.....	12	72	49959	50499599	Decal, sound.....	1
28*			Retaining ring, .750".....	1	73*			Backup ring.....	1
29*			O-ring, 1.625 x 1.750 x .062"–70.....	1					
30	43699	50436996	Strap, trigger.....	1					
31			Screw, cap, #10–32 x .375", button socket head.....	4					
32	42576	50425760	Trigger.....	1					
33	42547	50425471	Pivot, trigger.....	1					
34*			Retaining ring.....	2					
35*			O-ring, .437 x .562 x .062"–68.....	1					
36	43401	50434012	Washer, .75 x .50 x .03.....	1					
37	42865	50428651	Spring, valve plunger.....	1					
38*			O-ring, .562 x .750 x .093"–68.....	1					
39	41095	50410952	Cap.....	1					
40*			Retaining ring, .750".....	2					
41		52063245	Spool.....	1					
42	43556	50435566	Plug, spool.....	1					
43*			O-ring, .250 x .375 x .062"–90.....	1					
44*			Nut, 1/4–20, Hydra-Lok seal.....	2					

Repair Kit

*	49343G	50493434	Packing kit (includes items marked with an asterisk).....	1
---	--------	----------	---	---

Decals

49947	50499475	Decal, press/flow.....	1
48734	50487345	Decal, OC/CC setting.....	1
49946	50499467	Decal, warning.....	1
41547	50415471	Decal, Greenlee.....	1
06214	50062140	Decal, pinch warning.....	1
49959	50499599	Decal, sound.....	1

**Illustration—
LPK1240**

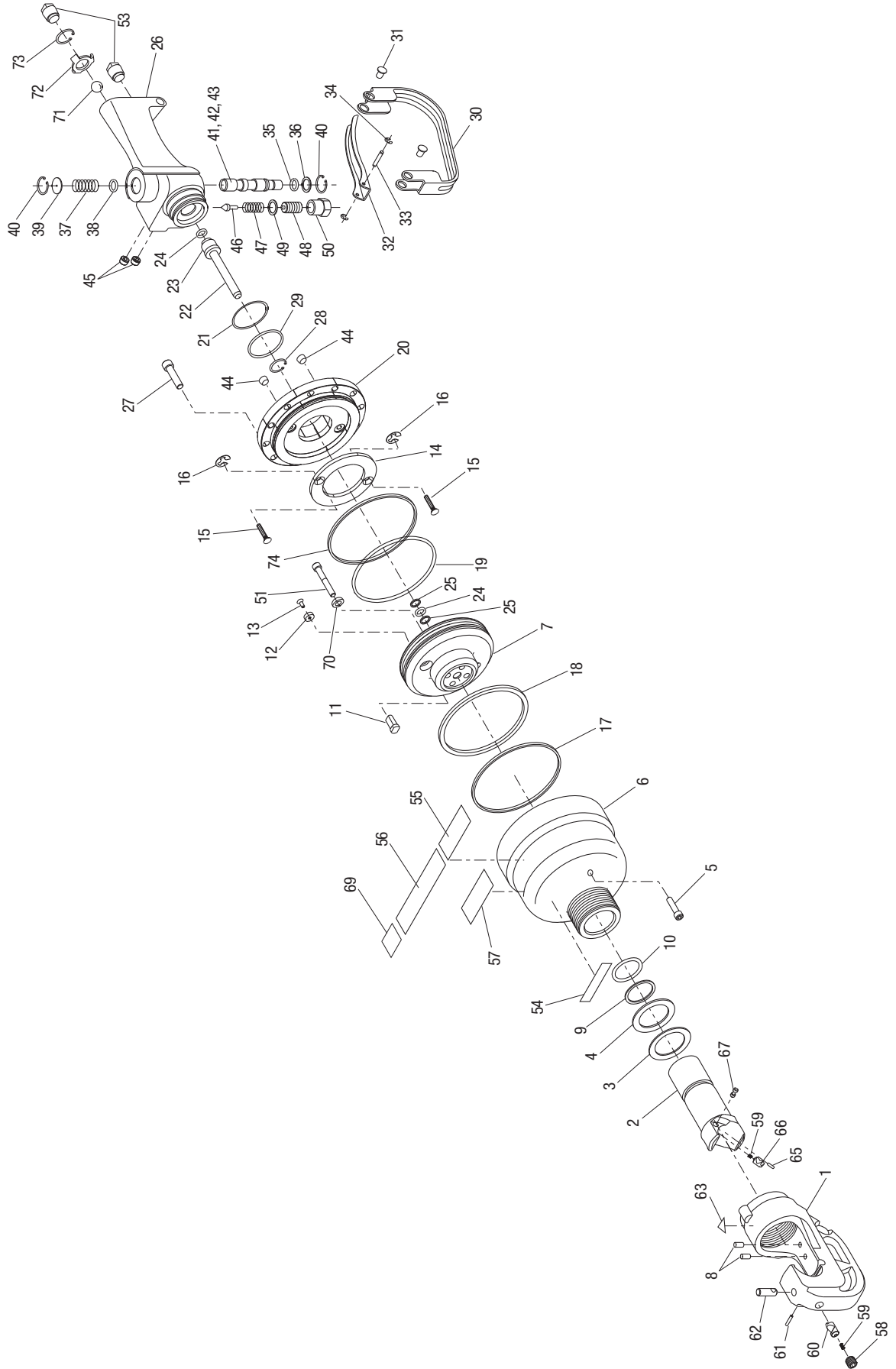

Parts List—LPK1240

Key	UPC No. 78-3310-	Part No.	Description	Qty	Key	UPC No. 78-3310-	Part No.	Description	Qty
1	49348	50493485	C-head unit (includes items 8, 58–63).....	1	42	43556	50435566	Plug, spool.....	1
2	49112G	50491121	Ram.....	1	43*			O-ring, .250 x .375 x .062"–90.....	1
3*			Washer, ram.....	1	44*			Nut, 1/4–20, Hydra-Lok seal.....	2
4*			Wiper, ram.....	1	45			Plug, pipe, 1/8" NPTF.....	2
5			Screw, cap, 1/4–20 x .87", socket head.....	1	46	30146	50301462	Pin, valve, .305 x .870".....	1
6	49349	50493493	Cylinder (includes items 54–57, 68, 69).....	1	47	40692	50406921	Spring, unloading valve.....	1
7	48733	50487337	Piston.....	1	48	48261	50482610	Screw, set, 1/2–20, adjusting.....	1
8	55062	90550625	Pin, groove (6 mm x 12 mm).....	2	49*			Washer, flat, .514 x .030, copper.....	1
9*			Backup ring, 1.375 x 1.62 x .121".....	1	50	48260G	50482602	Cap, relief valve.....	1
10*			O-ring, 1.375 x 1.62 x .125".....	1	51			Screw, cap, 1/4–20 x 1.625, socket.....	4
11	43546	50435469	Spool, shuttle.....	2	53	41432	50414323	Plug, port.....	2
12	43547	50435477	Washer, shuttle.....	2	54	49947	50499475	Decal, press/flow.....	1
13			Screw, cap, #6–32 x .375", flat head socket.....	2	55	48734	50487345	Decal, OC/CC setting.....	1
14	48727	50487272	Ring, shuttle stop.....	1	56	49946	50499467	Decal, warning.....	1
15	48728	50487280	Screw, stop ring.....	2	57	41547	50415471	Decal, Greenlee.....	1
16*			Retaining ring.....	2	58	55060	90550609	Screw, M12-1.75 x 12 mm set.....	1
17*			Backup ring, 4.312 x 4.500 x .125.....	1	59	03821	50038214	Spring.....	2
18*			Seal unit.....	1	60	05319	50053191	Pin, die retainer.....	1
19*			O-ring.....	1	61	55063G	90550633	Pin, grooved, 3 mm x 16 mm.....	1
20	45659	50456598	Cover, cylinder.....	1	62	05317	50053175	Button, die release.....	1
21	48737	50487370	Shim, handle.....	6 (max)	63	06214	50062140	Decal, pinch warning.....	1
22	43554	50435540	Tube.....	1	65	55064	90550641	Pin, roll 3 mm x 10 mm.....	1
23	42685	50426851	Carrier, seal.....	1	66	05316	50053167	Pin, die retainer.....	1
24*			O-ring, .375 x .500 x .062"–70.....	2	67	05318	50053183	Button, die release.....	1
25*			Backup ring, .382 x .486 x .045".....	2	69	49959	50499599	Decal, sound.....	1
26	48736	50487361	Handle.....	1	70	54913	90549139	Washer, conical, .55 x .25 x .05.....	4
27			Screw, cap, 5/16–18 x 1.25", socket head.....	12	71	41873	50418730	Ball, steel, .5".....	1
28*			Retaining ring, .750".....	1	72	49234	50492349	Stop, ball.....	1
29*			O-ring, 1.625 x 1.750 x .062"–70.....	1	73	41600	50416003	Retaining ring, .687.....	1
30	43699	50436996	Strap, trigger.....	1	74*			Backup ring.....	1
31			Screw, cap, #10–32 x .375", button socket head.....	4	Repair Kit				
32	42576	50425760	Trigger.....	1	*	49343G	50493434	Packing kit (includes items marked with an asterisk).....	1
33	42547	50425471	Pivot, trigger.....	1	Decals				
34*			Retaining ring.....	2	49947	50499475	Decal, press/flow.....	1	
35*			O-ring, .437 x .562 x .062"–68.....	1	48734	50487345	Decal, OC/CC setting.....	1	
36	43401	50434012	Washer, .75 x .50 x .03.....	1	49946	50499467	Decal, warning.....	1	
37	42865	50428651	Spring, valve plunger.....	1	41547	50415471	Decal, Greenlee.....	1	
38*			O-ring, .562 x .750 x .093"–68.....	1	06214	50062140	Decal, pinch warning.....	1	
39	41095	50410952	Cap.....	1	49959	50499599	Decal, sound.....	1	
40*			Retaining ring, .750".....	2					
41		52063245	Spool.....	1					

**Illustration—
LPK1240K**

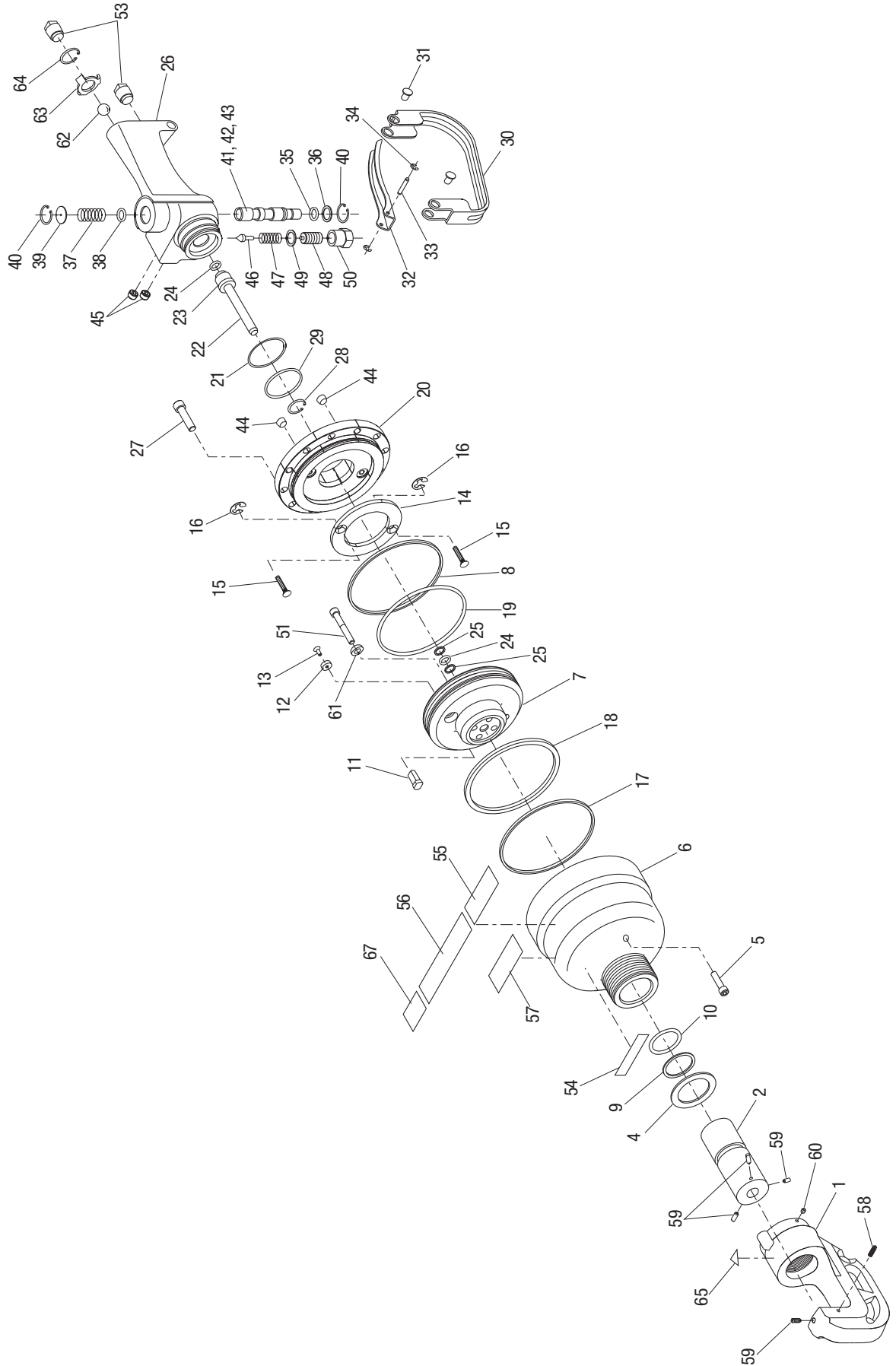

Parts List—LPK1240K

Key	UPC No. 78-3310-	Part No.	Description	Qty
1	05476	50054767	C-head unit (includes items 58-60, 65).....	1
2	49351	50493515	Ram	1
4*			Wiper, ram.....	1
5			Screw, cap, 1/4-20 x .87", socket head	1
6	49349	50493493	Cylinder (includes items 54-57, 66, 67).....	1
7	48733	50487337	Piston.....	1
8*			Backup ring.....	1
9*			Backup ring, 1.375 x 1.62 x .121"	1
10*			O-ring, 1.375 x 1.62 x .125"	1
11	43546	50435469	Spool, shuttle.....	2
12	43547	50435477	Washer, shuttle	2
13			Screw, cap, #6-32 x .375", flat head socket	2
14	48727	50487272	Ring, shuttle stop.....	1
15	48728	50487280	Screw, stop ring.....	2
16*			Retaining ring.....	2
17*			Backup ring, 4.312 x 4.500 x .125.....	1
18*			Seal unit.....	1
19*			O-ring.....	1
20	45659	50456598	Cover, cylinder	1
21	48737	50487370	Shim, handle.....	6 (max)
22	43554	50435540	Tube	1
23	42685	50426851	Carrier, seal	1
24*			O-ring, .375 x .500 x .062"-70.....	2
25*			Backup ring, .382 x .486 x .045"	2
26	48736	50487361	Handle.....	1
27			Screw, cap, 5/16-18 x 1.25", socket head	12
28*			Retaining ring, .750"	1
29*			O-ring, 1.625 x 1.750 x .062"-70.....	1
30	43699	50436996	Strap, trigger.....	1
31			Screw, cap, #10-32 x .375", button socket head.....	4
32	42576	50425760	Trigger	1
33	42547	50425471	Pivot, trigger	1
34*			Retaining ring.....	2
35*			O-ring, .437 x .562 x .062"-68.....	1
36	43401	50434012	Washer, .75 x .50 x .03.....	1
37	42865	50428651	Spring, valve plunger.....	1
38*			O-ring, .562 x .750 x .093"-68.....	1
39	41095	50410952	Cap	1
40*			Retaining ring, .750"	2
41		52063245	Spool.....	1
42	43556	50435566	Plug, spool.....	1
43*			O-ring, .250 x .375 x .062"-90.....	1
44*			Nut, 1/4-20, Hydra-Lok seal.....	2
45			Plug, pipe, 1/8" NPTF	2
46	30146	50301462	Pin, valve, .305 x .870"	1
47	40692	50406921	Spring, unloading valve	1
48	48261	50482610	Screw, set, 1/2-20, adjusting.....	1
49*			Washer, flat, .514 x .030, copper	1
50	48260G	50482602	Cap, relief valve	1
51			Screw, cap, 1/4-20 x 1.625, socket.....	4
53	41432	50414323	Plug, port	2
54	49947	50499475	Decal, press/flow	1
55	48734	50487345	Decal, OC/CC setting	1
56	49946	50499467	Decal, warning	1
57	41547	50415471	Decal, Greenlee	1
58			Screw, #10-32 x .500 set.....	1
59	53962	90539621	Spring, plunger, #10-32 x 5.00	4
60	55061	90550617	Screw, M5-.8 x 5 mm set	1
61	54913	90549139	Washer, conical, .55 x .25 x .05.....	4
62	41873	50418730	Ball, steel, .5"	1
63	49234	50492349	Stop, ball.....	1
64	41600	50416003	Retaining ring, .687.....	1
65	06214	50062140	Decal, pinch warning	1
67	49959	50499599	Decal, sound.....	1
Repair Kit				
*	49343G	50493434	Packing Kit (includes items marked with an asterisk).....	1
Decals				
	49947	50499475	Decal, press/flow	1
	48734	50487345	Decal, OC/CC setting	1
	49946	50499467	Decal, warning	1
	41547	50415471	Decal, Greenlee	1
	06214	50062140	Decal, pinch warning	1
	49959	50499599	Decal, sound.....	1

**Illustration—
LPK1550**

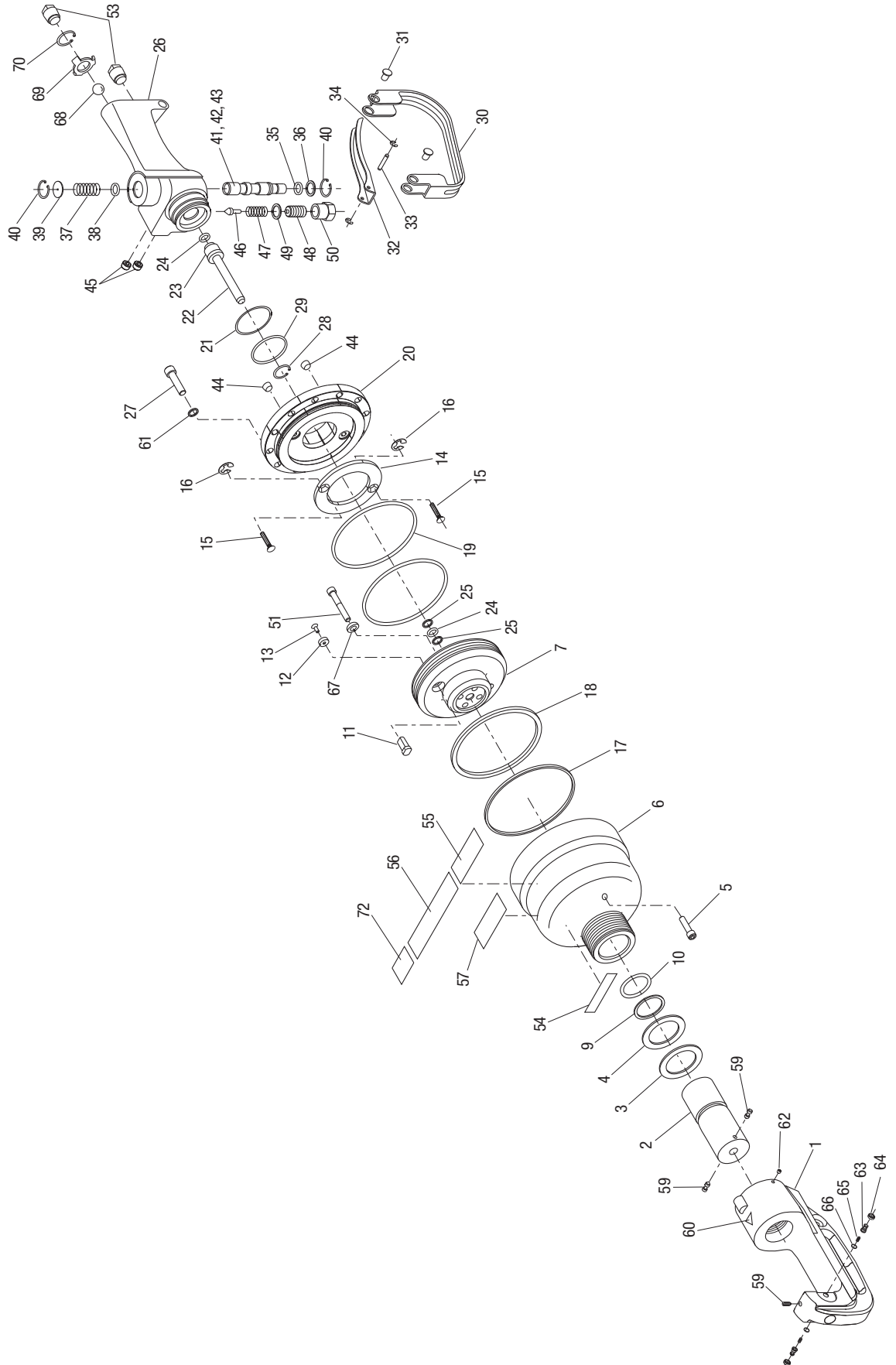

Parts List—LPK1550

Key	UPC No. 78-3310-	Part No.	Description	Qty	Key	UPC No. 78-3310-	Part No.	Description	Qty
1	49352	50493523	C-head unit (includes items 59, 60, 62–66).....	1	42	43556	50435566	Plug, spool.....	1
2	49357	50493574	Ram.....	1	43*			O-ring, .250 x .375 x .062"–90.....	1
3*			Washer.....	1	44*			Nut, 1/4–20, Hydra-Lok seal.....	2
4*			Wiper.....	1	45			Plug, pipe, 1/8" NPTF.....	2
5			Screw, cap, 1/4–20 x 1.00", socket head.....	1	46	30146	50301462	Pin, valve, .305 x .870".....	1
6	49359	50493590	Cylinder (includes items 54–57, 71–72).....	1	47	40692	50406921	Spring, unloading valve.....	1
7	48795	50487957	Piston.....	1	48	48261	50482610	Screw, set, 1/2–20, adjusting.....	1
9*			Backup ring, 1.37 x 1.62 x .121".....	1	49*			Washer, flat, .514 x .030, copper.....	1
10*			O-ring, 1.37 x 1.62 x .125".....	1	50	48260G	50482602	Cap, relief valve.....	1
11	43546	50435469	Spool, shuttle.....	2	51			Screw, cap, 1/4–20 x 1.625, socket.....	4
12	43547	50435477	Washer, shuttle.....	2	52*			Backup ring.....	1
13			Screw, cap, #6–32 x .375", flat head socket.....	2	53	41432	50414323	Plug, port.....	2
14	48727	50487272	Ring, shuttle stop.....	1	54	49947	50499475	Decal, specifications.....	1
15	48881	50488813	Screw.....	2	55	48734	50487345	Decal, OC/CC setting.....	1
16*			Retaining ring.....	2	56	49946	50499467	Decal, warning.....	1
17*			Ring.....	1	57	41547	50415471	Decal, Greenlee.....	1
18*			Seal unit.....	1	59	53962	90539621	Plunger, spring #10-32 x .500.....	3
19*			O-ring, 5.125".....	1	60	06214	50062140	Decal, pinch warning.....	1
20	49898	50498983	Cover.....	1	61	54813	90548132	Washer, flat .344 x .688 x .060".....	16
21	48737	50487370	Shim, handle.....	6 (max)	62			Screw, set #10-32 x .187 socket head.....	1
22	43554	50435540	Tube.....	1	63	05434	50054341	Button, die retainer.....	2
23	42685	50426851	Carrier, seal.....	1	64	05435	50054350	Nut, retaining.....	2
24*			O-ring, .375 x .500 x .062"–70.....	2	65	05433	50054333	Spring, compression.....	2
25*			Backup ring, .382 x .486 x .045".....	2	66	05432	50054325	Disc, flat.....	2
26	48736	50487361	Handle.....	1	67	54913	90549139	Washer, conical, .55 x .25 x .05.....	4
27			Screw, cap, 5/16–18 x 1.25", socket head.....	16	68	41873	50418730	Ball, steel, .5".....	1
28*			Retaining ring, .750".....	1	69	49234	50492349	Stop, ball.....	1
29*			O-ring, 1.625 x 1.750 x .062"–70.....	1	70*			Retaining ring.....	1
30	43699	50436996	Strap, trigger.....	1	72	49959	50499599	Decal, sound.....	1
31			Screw, cap, #10–32 x .375", button socket head.....	4	Repair Kit				
32	42576	50425760	Trigger.....	1	*	49358	50493582	Packing kit (includes items marked with an asterisk).....	1
33	42547	50425471	Pivot, trigger.....	1	Decals				
34*			Retaining ring.....	2	49947	50499475		Decal, specifications.....	1
35*			O-ring, .437 x .562 x .062"–68.....	1	48734	50487345		Decal, OC/CC setting.....	1
36	43401	50434012	Washer, .75 x .50 x .03.....	1	49946	50499467		Decal, warning.....	1
37	42865	50428651	Spring, valve plunger.....	1	41547	50415471		Decal, Greenlee.....	1
38*			O-ring, .562 x .750 x .093"–68.....	1	06214	50062140		Decal, pinch warning.....	1
39	41095	50410952	Cap.....	1	49959	50499599		Decal, sound.....	1
40*			Retaining ring, .750".....	2					
41		52063245	Spool.....	1					

**Illustration—
LPK1550FT**

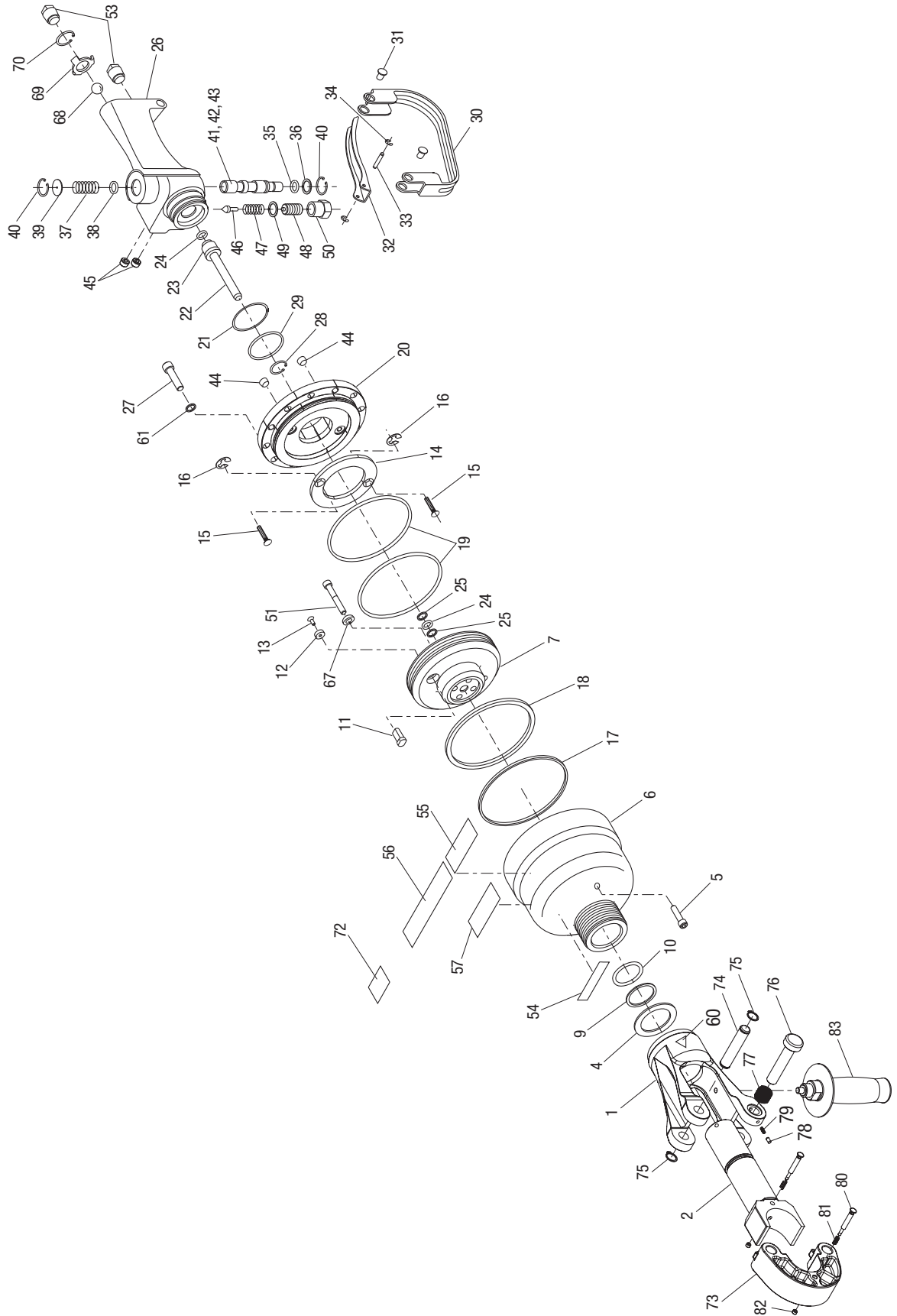

Parts List—LPK1550FT

Key	UPC No. 78-3310-	Part No.	Description	Qty	Key	UPC No. 78-3310-	Part No.	Description	Qty
1	00708	52060925	Head unit (includes items 73–82).....	1	46	30146	50301462	Pin, valve, .305 x .870"	1
2	00709	52059554	Ram	1	47	40692	50406921	Spring, unloading valve	1
4*			Wiper.....	1	48	48261	50482610	Screw, set, 1/2–20, adjusting.....	1
5			Screw, cap, 1/4–20 x 1.00", socket head	1	49*			Washer, flat, .514 x .030, copper	1
6	49359	50493590	Cylinder (includes items 54–57, 71–72).....	1	50	48260G	50482602	Cap, relief valve	1
7	48795	50487957	Piston.....	1	51			Screw, cap, 1/4–20 x 1.625, socket.....	4
9*			Backup ring, 1.37 x 1.62 x .121"	1	52*			Backup ring.....	1
10*			O-ring, 1.37 x 1.62 x .125".....	1	53	41432	50414323	Plug, port	2
11	43546	50435469	Spool, shuttle.....	2	54	49947	50499475	Decal, specifications.....	1
12	43547	50435477	Washer, shuttle	2	55	48734	50487345	Decal, OC/CC setting	1
13			Screw, cap, #6–32 x .375", flat head socket	2	56	49946	50499467	Decal, warning	1
14	48727	50487272	Ring, shuttle stop.....	1	57	41547	50415471	Decal, Greenlee	1
15	48881	50488813	Screw.....	2	60	06214	50062140	Decal, pinch warning	1
16*			Retaining ring.....	2	61	54813	90548132	Washer, flat .344 x .688 x .060"	16
17*			Ring.....	1	67	54913	90549139	Washer, conical, .55 x .25 x .05.....	4
18*			Seal unit.....	1	68	41873	50418730	Ball, steel, .5"	1
19*			O-ring, 5.125"	1	69	49234	50492349	Stop, ball.....	1
20	49898	50498983	Cover	1	70*			Retaining ring.....	1
21	48737	50487370	Shim, handle.....	6 (max)	72	49959	50499599	Decal, sound.....	1
22	43554	50435540	Tube	1	73			Head	1
23	42685	50426851	Carrier, seal.....	1	74			Pin.....	1
24*			O-ring, .375 x .500 x .062"–70.....	2	75			Retaining ring.....	2
25*			Backup ring, .382 x .486 x .045"	2	76			Pin, pull	1
26	48736	50487361	Handle.....	1	77			Spring, compression.....	1
27			Screw, cap, 5/16–18 x 1.25", socket head	16	78			Pin, lock	1
28*			Retaining ring, .750"	1	79			Spring, compression.....	1
29*			O-ring, 1.625 x 1.750 x .062"–70.....	1	80			Pin, die release.....	2
30	43699	50436996	Strap, trigger.....	1	81			Spring, compression.....	2
31			Screw, cap, #10–32 x .375", button socket head.....	4	82			Button, die release.....	2
32	42576	50425760	Trigger	1	83	23492	52020646	Handle (optional).....	1
33	42547	50425471	Pivot, trigger	1	Repair Kits				
34*			Retaining ring.....	2	*	49358	50493582	Packing kit (includes items marked with an asterisk).....	1
35*			O-ring, .437 x .562 x .062"–68.....	1		00704	52062270	Die pin kit (includes two each of items 80–82)	
36	43401	50434012	Washer, .75 x .50 x .03.....	1		00705	52062271	Pivot pin kit (includes items 74–79)	
37	42865	50428651	Spring, valve plunger.....	1	Decals				
38*			O-ring, .562 x .750 x .093"–68.....	1		49947	50499475	Decal, specifications.....	1
39	41095	50410952	Cap	1		48734	50487345	Decal, OC/CC setting	1
40*			Retaining ring, .750"	2		49946	50499467	Decal, warning	1
41		52063245	Spool.....	1		41547	50415471	Decal, Greenlee	1
42	43556	50435566	Plug, spool.....	1		06214	50062140	Decal, pinch warning	1
43*			O-ring, .250 x .375 x .062"–90.....	1		49959	50499599	Decal, sound.....	1
44*			Nut, 1/4–20, Hydra-Lok seal.....	2	Accessories				
45			Plug, pipe, 1/8" NPTF.....	2		00260	52060610	UA15T "U" die adapter set	1



4455 Boeing Drive • Rockford, IL 61109-2988 • USA • 815-397-7070
©2019 Greenlee Tools, Inc. • An ISO 9001 Company

www.greenlee.com

USA Tel: 800-435-0786
Fax: 800-451-2632

Canada Tel: 800-435-0786
Fax: 800-524-2853

International Tel: +1-815-397-7070
Fax: +1-815-397-9247