

# INSTRUCTION MANUAL

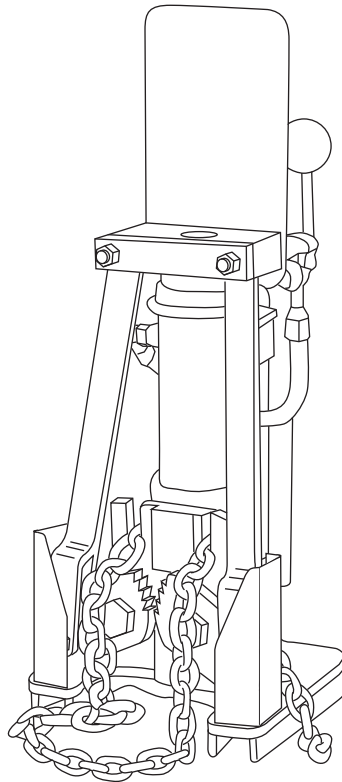

## **H4905A**

# **Hydraulic Sign Post Puller**



**Read and understand** all of the instructions and safety information in this manual before operating or servicing this tool.

Register this product at [www.greenlee.com](http://www.greenlee.com)

## Table of Contents

Description .....	2
Safety .....	2
Purpose of this Manual .....	2
Other Publications .....	2
Important Safety Information .....	3-5
Identification .....	6
Specifications .....	7
Hoses and Fittings .....	8
Hose Connections .....	8
Typical Setup .....	8
Operation .....	9-10
Maintenance .....	10
Troubleshooting .....	11
Illustration and Parts List .....	12-13

## Description

The H4905A is a portable, hydraulically powered device intended to pull various sizes and shapes of standard sign posts. Capable of developing 43.6 kN (9800 lb) of lifting force, the sign post puller uses either serrated jaws or a chain to grip the post. It features a built-in control valve.

## Safety

Safety is essential in the use and maintenance of Greenlee tools and equipment. This instruction manual and any markings on the tool provide information for avoiding hazards and unsafe practices related to the use of this tool. Observe all of the safety information provided.

## Purpose of this Manual

This manual is intended to familiarize personnel with the safe operation and maintenance procedures for the following Greenlee tool:

H4905A (42237) Sign Post Puller

Keep this manual available to all personnel.

Replacement manuals are available upon request at no charge at [www.greenlee.com](http://www.greenlee.com).

## Other Publications

### Tool Owners/Users

SAE Standard J1273 (Hose and Hose Assemblies):  
Publication 99930323

### Authorized Greenlee Service Centers

Service Manual: Publication 99916045

All specifications are nominal and may change as design improvements occur. Greenlee Tools, Inc. shall not be liable for damages resulting from misapplication or misuse of its products.

# ***KEEP THIS MANUAL***

## IMPORTANT SAFETY INFORMATION

	<h3 style="margin: 0;">SAFETY ALERT SYMBOL</h3>
<p>This symbol is used to call your attention to hazards or unsafe practices which could result in an injury or property damage. The signal word, defined below, indicates the severity of the hazard. The message after the signal word provides information for preventing or avoiding the hazard.</p>	
<h3 style="margin: 0;">⚠ DANGER</h3>	
<p>Immediate hazards which, if not avoided, <b>WILL</b> result in severe injury or death.</p>	
<h3 style="margin: 0;">⚠ WARNING</h3>	
<p>Hazards which, if not avoided, <b>COULD</b> result in severe injury or death.</p>	
<h3 style="margin: 0;">⚠ CAUTION</h3>	
<p>Hazards or unsafe practices which, if not avoided, <b>MAY</b> result in injury or property damage.</p>	

	<h3 style="margin: 0;">⚠ WARNING</h3>
<p>Skin injection hazard:</p> <ul style="list-style-type: none"> <li>• Do not use hands to check for leaks.</li> <li>• Do not hold hose or couplers while the hydraulic system is pressurized.</li> <li>• Depressurize the hydraulic system before servicing.</li> </ul> <p>Oil under pressure easily punctures skin, causing serious injury, gangrene, or death. If you are injured by escaping oil, seek medical attention immediately.</p>	

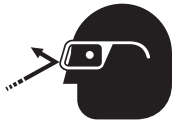
	<h3 style="margin: 0;">⚠ WARNING</h3>
<p>Wear eye protection when operating or servicing this tool.</p> <p>Failure to wear eye protection could result in serious eye injury from flying debris or hydraulic oil.</p>	

	<h3 style="margin: 0;">⚠ WARNING</h3>
<p>Wear a hard hat when using this tool.</p> <p>Failure to observe this warning could result in severe injury or death.</p>	

	<h3 style="margin: 0;">⚠ WARNING</h3>
<p>Read and understand all of the instructions and safety information in this manual before operating or servicing this tool.</p> <p>Failure to observe this warning could result in severe injury or death.</p>	

	<h3 style="margin: 0;">⚠ WARNING</h3>
<p>Pinch points:</p> <p>Keep hands away from moving parts during operation.</p> <p>Failure to observe this warning could result in severe injury or death.</p>	

	<h3 style="margin: 0;">⚠ WARNING</h3>
<p>Electric shock hazard:</p> <p>This tool is not insulated. Do not use this tool near energized electrical lines.</p> <p>Failure to observe this warning could result in severe injury or death.</p>	

	<h3 style="margin: 0;">⚠ WARNING</h3>
<p>Wear hearing protection when using this tool.</p> <p>Long-term exposure to high noise levels could result in hearing loss.</p>	

## **IMPORTANT SAFETY INFORMATION**

	<b>⚠ WARNING</b>
	<p>Wear foot protection when using this tool.</p> <p>Failure to observe this warning could result in serious injury.</p>

	<b>⚠ WARNING</b>
	<p>Tool and other components may be hot during and after operation. Allow to cool before handling, or handle with heat-resistant gloves.</p> <p>Failure to observe this warning could result in severe injury.</p>

<b>⚠ WARNING</b>
<p>Support or secure the post that is being removed. An unsupported or unsecured post can fall.</p> <p>Failure to observe this warning could result in severe injury or death.</p>

<b>⚠ WARNING</b>
<p>Use chains with the following characteristics:</p> <ul style="list-style-type: none"><li>• 7.1 mm (9/32") link thickness</li><li>• Alloy steel material</li><li>• 64 kN (14,400 lb) minimum breaking strength</li></ul> <p>An underrated chain may break during operation.</p> <p>Failure to observe this warning could result in severe injury or death.</p>

<b>⚠ WARNING</b>
<p>Do not exceed the following hydraulic power source maximums:</p> <ul style="list-style-type: none"><li>• Hydraulic flow: 22.7 l/min (6 gpm)</li><li>• Pressure relief: 138 bar (2000 psi)</li><li>• Back pressure: 13.8 bar (200 psi)</li></ul> <p>Failure to observe this warning could result in severe injury or death.</p>

<b>⚠ WARNING</b>
<p>Do not disconnect tool, hoses, or fittings while the power source is running or if the hydraulic fluid is hot. Hot hydraulic fluid could cause serious burns.</p>

<b>⚠ WARNING</b>
<p>Do not reverse hydraulic flow. Operation with hydraulic flow reversed can cause tool malfunction. Connect the pressure (supply) hose and tank (return) hose to the proper ports.</p>

<b>⚠ WARNING</b>
<p>Do not change accessories, inspect, adjust, or clean tool when it is connected to a power source. Accidental start-up can result in serious injury.</p> <p>Failure to observe this warning could result in severe injury or death.</p>

## **IMPORTANT SAFETY INFORMATION**

### **⚠ CAUTION**

Hydraulic oil can cause skin irritation.

- Handle the tool and hoses with care to prevent skin contact with hydraulic oil.
- In case of accidental skin contact with hydraulic oil, wash the affected area immediately to remove the oil.

Failure to observe these precautions may result in injury.

### **⚠ CAUTION**

- Inspect the hydraulic hoses and couplers every operating day. Repair or replace if leakage, cracking, wear, or damage is evident. Damaged hoses or couplers may fail, resulting in injury or property damage.
- Use this tool for manufacturer's intended purpose only. Use other than that which is described in this manual may result in injury or property damage.
- Make sure all bystanders are clear of the work area when handling, starting, and operating the tool. Nearby personnel may be injured by flying or falling debris or by flying parts in the event of a tool malfunction.

### **IMPORTANT**

Emergency stop procedure/power supply failure:

1. Release the control lever.
2. Shut off the hydraulic power source.

### **IMPORTANT**

Procedure for connecting or disconnecting hydraulic hoses, fittings, or components:

1. Move the flow lever on the hydraulic power source to the OFF position.
2. Stop the hydraulic power source.
3. Follow the sequence under "Hose Connections" in the Instruction Manual to prevent pressure buildup. In case some pressure has built up, loosen hoses, fittings, or components slowly.

*Note: Keep all decals clean and legible, and replace when necessary.*

**Identification**

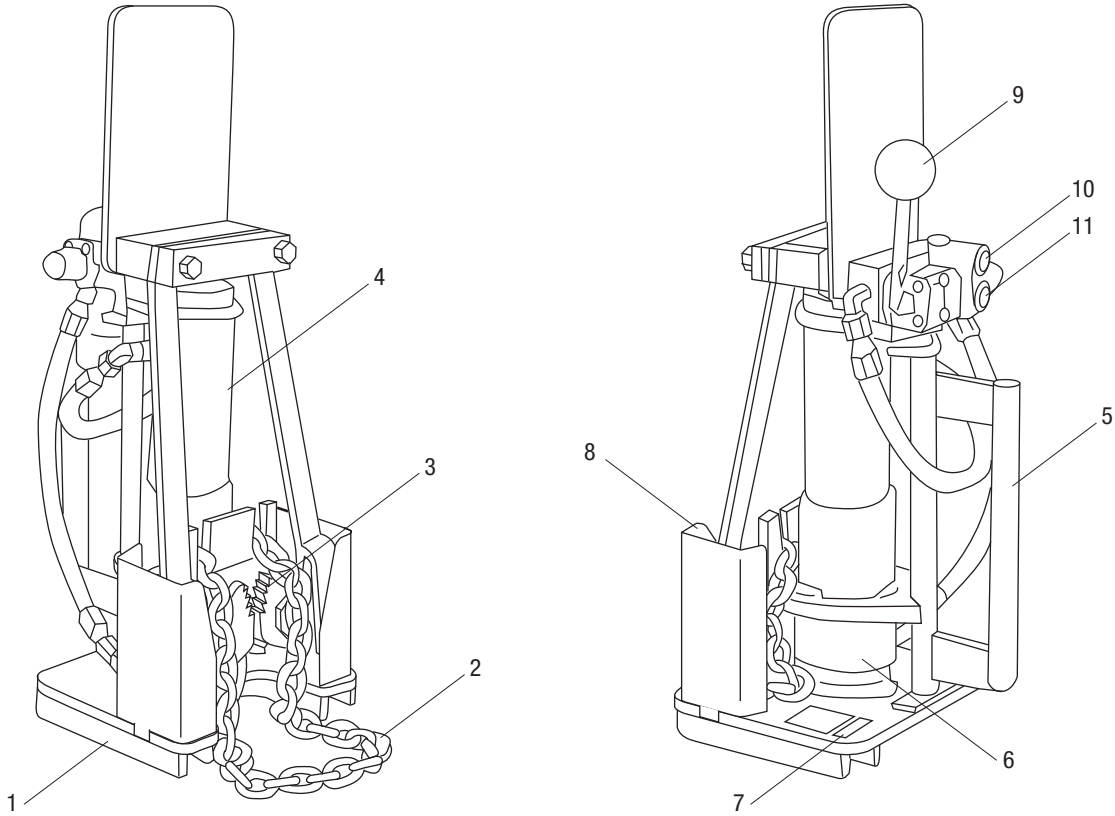

- 1. Base
- 2. Chain
- 3. Serrated Jaws
- 4. Cylinder
- 5. Handle
- 6. Guide
- 7. Serial Number
- 8. Bracket
- 9. Control Lever
- 10. Pressure (supply) Port
- 11. Tank (return) Port

## Specifications

### Sign Post Puller

Type of Hydraulic System: Open-center

Hydraulic Ports:

Pressure (supply): 9/16–18 SAE O-ring boss

Tank (return): 3/4–16 SAE O-ring boss

Lifting Force: 43.6 kN (9800 lb)

Stroke: 127 mm (5")

Sound Power Level: 32 LWA

Mass/Weight: 32 kg (70 lb)

Height: 660 mm (26")

Width: 254 mm (10")

Length: 267 mm (10.5")

### Hydraulic Power Source

#### **⚠ WARNING**

Do not exceed the following hydraulic power source maximums:

- Hydraulic flow: 22.7 l/min (6 gpm)
- Pressure relief: 138 bar (2000 psi)
- Back pressure: 13.8 bar (200 psi)

Failure to observe this warning could result in severe injury or death.

Type of Hydraulic System: Open-center

Flow:

Minimum: 15.1 l/min (4 gpm)

Recommended: 18.9 l/min (5 gpm)

Maximum: 22.7 l/min (6 gpm)

Filtration: 10 micron (nominal)

Pressure Relief Setting: 138 bar (2000 psi)

Back Pressure (maximum\*): 13.8 bar (200 psi)

\* 13.8 bar (200 psi) is the maximum agreed standard back pressure for the HTMA (Hydraulic Tool Manufacturers Association). Greenlee tools will operate satisfactorily at this standard.

1. Maximum hydraulic fluid temperature must not exceed 60 °C (140 °F). A sufficient oil cooling capacity is needed to limit the hydraulic fluid temperature.
2. Hydraulic flow must not exceed 22.7 l/min (6 gpm). Install a flow meter in the return line to measure the rate of hydraulic flow before using the tool.
3. Pressure relief valve setting must not exceed 138 bar (2000 psi) at your tool's maximum flow. Locate the pressure relief valve in the supply circuit to limit excessive hydraulic pressure to the tool.

### Hydraulic Schematic

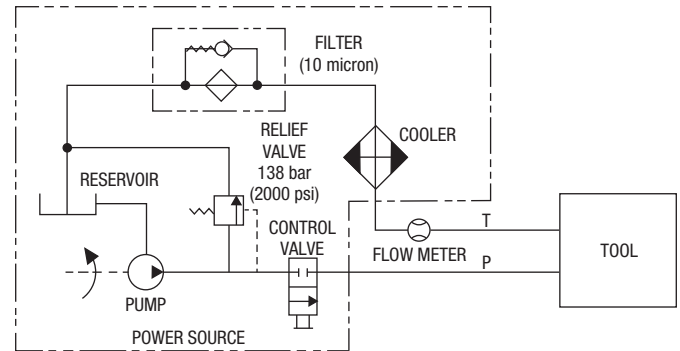

### Recommended Hydraulic Fluids

Use any nondetergent, petroleum-based hydraulic fluid which meets the following specifications or HTMA specifications.

S.U.S. @:

38 °C (100 °F): 140 to 225

99 °C (210 °F): 40 minimum

Flash Point: 170 °C (340 °F) minimum

Pour Point: -34 °C (-30 °F) minimum

## Hoses and Fittings

### Installation and Maintenance

Refer to publication 99930323, SAE J1273 (Hose and Hose Assemblies).

### Replacement

Refer to a Greenlee catalog or publication 99910322, Low Pressure Quick Couplers, Adapters, and Hoses.

## WARNING

Do not disconnect tool, hoses, or fittings while the power source is running or if the hydraulic fluid is hot. Hot hydraulic fluid could cause serious burns.

## Hose Connections

### Connecting Hoses

1. Move the flow lever on the hydraulic power source to the OFF position.
2. Stop the hydraulic power source.
3. Connect the tank hose to the tank (return) port on the hydraulic power source, and then to the tank port on the tool.
4. Connect the pressure hose to the pressure port on the tool, and then to the pressure (supply) port on the hydraulic power source.

### Disconnecting Hoses

1. Move the flow lever on the hydraulic power source to the OFF position.
2. Stop the hydraulic power source.
3. Disconnect the pressure hose from the hydraulic power source, and then from the tool.
4. Disconnect the tank hose from the tool, and then from the hydraulic power source.
5. Install dust caps over the ports to prevent contamination.

## Typical Setup

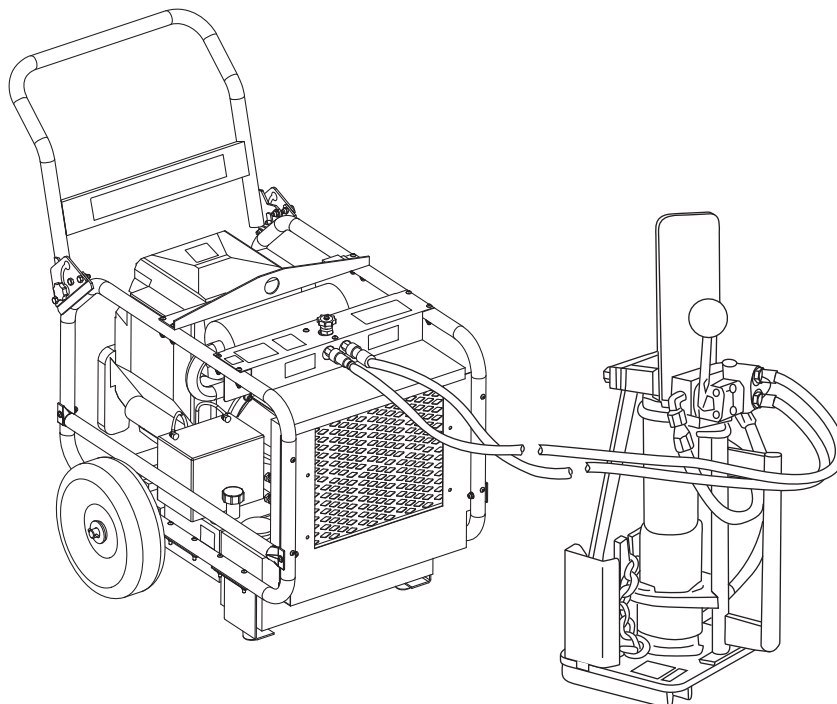



**Operation**

	<b>⚠ WARNING</b>
	<p>Electric shock hazard: This tool is not insulated. Do not use this tool near energized electrical lines.</p> <p>Failure to observe this warning could result in severe injury or death.</p>

	<b>⚠ WARNING</b>
	<p>Pinch points: Keep hands away from moving parts during operation.</p> <p>Failure to observe this warning could result in severe injury or death.</p>

<b>⚠ WARNING</b>
<p>Support or secure the post that is being removed. An unsupported or unsecured post can fall.</p> <p>Failure to observe this warning could result in severe injury or death.</p>

<b>⚠ WARNING</b>
<p>Do not change accessories, inspect, adjust, or clean tool when it is connected to a power source. Accidental start-up can result in serious injury.</p> <p>Failure to observe this warning could result in severe injury or death.</p>

<b>⚠ CAUTION</b>
<p>Make sure all bystanders are clear of the work area when handling, starting, and operating the tool. Nearby personnel may be injured by flying or falling debris or by flying parts in the event of a tool malfunction.</p>

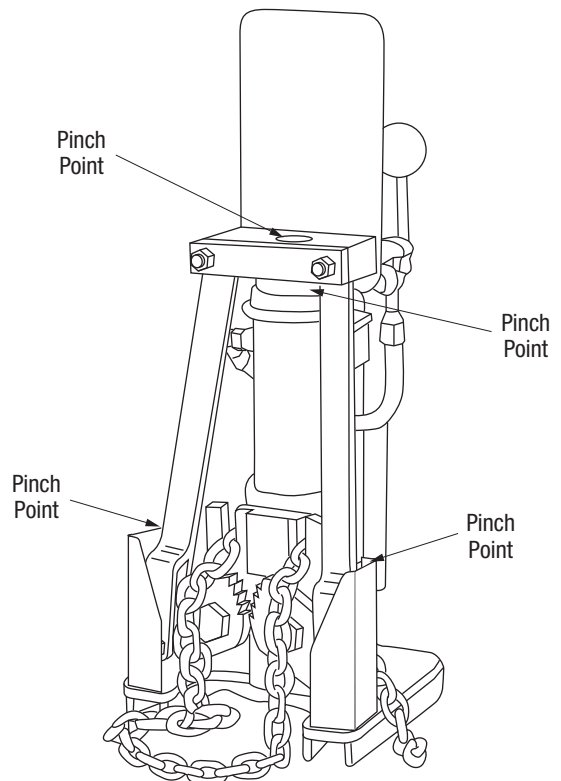

*Note: Maintain proper footing and balance while using the tool. Do not overreach. Unsuitable footing and balance may not allow counteracting normal or unexpected movement of the tool.*

## Operation (cont'd)

1. Start the hydraulic power source.  
*Note: Allow the hydraulic power source to run for a few minutes to warm the hydraulic fluid.*
2. Support or secure the post so that it will not fall when it is extracted.
3. Position the sign post puller next to the post that is to be pulled. Level the area for a vertical pull.
4. Use either the jaws or chain as follows:
  - Serrated jaws: Position the jaws so that they firmly grip the post flange.
  - Chain: Wrap the chain twice around the post. Leaving some slack in the chain, slide one link into each of the slots in the guide.

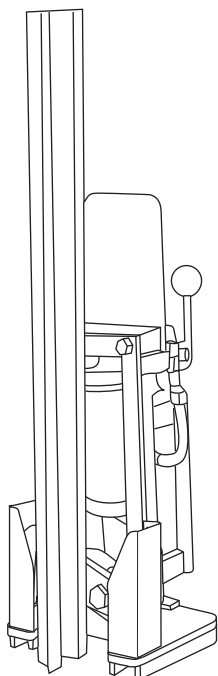

**Using Serrated Jaws**

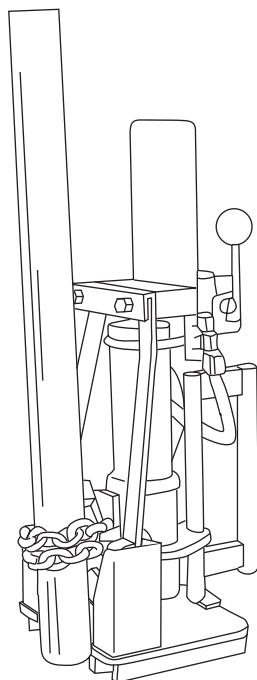

**Using Chain**

5. Extend and retract the cylinder until the post is extracted from the ground.
6. When the tool is not in use, stop the hydraulic power source to reduce heat and wear on tool components.

## IMPORTANT

Emergency stop procedure/power supply failure:

1. Release the control lever.
2. Shut off the hydraulic power source.

## Maintenance

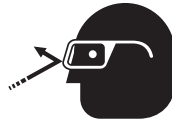
	<p style="text-align: center;"><b>⚠ WARNING</b></p> <p>Wear eye protection when operating or servicing this tool.</p> <p>Failure to wear eye protection could result in serious eye injury from flying debris or hydraulic oil.</p>
---	---

<p><b>⚠ WARNING</b></p>
<p>Do not change accessories, inspect, adjust, or clean tool when it is connected to a power source. Accidental start-up can result in serious injury.</p> <p>Failure to observe this warning could result in severe injury or death.</p>

Use this maintenance schedule to maximize the tool's service life.

*Notes: Keep all decals clean and legible. Replace decals when necessary.*

*When disposing of any components (hydraulic hoses, hydraulic fluid, worn parts, etc.), do so in accordance with federal, state, and local laws or ordinances.*

### Daily

1. Wipe all tool surfaces clean.
2. Inspect the chains for signs of cracks, damage, corrosion, or deformed links. Replace if necessary.
3. Inspect the hydraulic hoses and fittings for signs of leaks, cracks, wear, or damage. Replace if necessary.
4. Install dust caps over the hydraulic ports when the tool is disconnected.

### Monthly

Perform a thorough inspection of the hydraulic hoses and fittings as described in publication 99930323, SAE J1273 (Hose and Hose Assemblies).

### Annually

Some organizations require an annual inspection. Have the tool inspected by a Greenlee Authorized Service Center.

## Troubleshooting

Before troubleshooting, determine whether the problem is in the tool, the hoses, or the power source. Substitute a tool, hoses, or power source known to be in good working order to eliminate the item that is not operating.

If the problem is in the tool, refer to the troubleshooting table in this manual. If the problem is in the power source, refer to the troubleshooting section of the power source instruction manual.

<b>Problem</b>	<b>Probable Cause</b>	<b>Probable Remedy</b>
Tool does not operate.	Improper power source.	Verify that the power source meets the specifications.
	Hydraulic fluid level low.	Check the fluid level. Check system for leaks.
	Incorrect hydraulic fluid viscosity.	Use hydraulic fluid with the correct viscosity.
Tool operates slowly or erratically.	Hydraulic fluid cold.	Allow fluid to warm to the operating temperature. Actuate the tool intermittently to reduce the warming time.
	Power source not adjusted correctly.	Refer to the power source operator's manual. Set the flow and pressure to correspond with the tool.
	Hydraulic fluid level low.	Check the fluid level. Check system for leaks.
	Air in the hydraulic system.	Refer to the power source manufacturer's instructions for removing air from the system.
	Incorrect hydraulic fluid viscosity.	Use hydraulic fluid with the correct viscosity.
Tool feels hot.	Hydraulic fluid level low.	Check the fluid level. Check for leaks.
	Incorrect hydraulic fluid viscosity.	Use hydraulic fluid with the correct viscosity.
	Hydraulic fluid dirty.	Refer to the power source owner's manual for procedure to replace hydraulic oil and filter.

**Illustration**

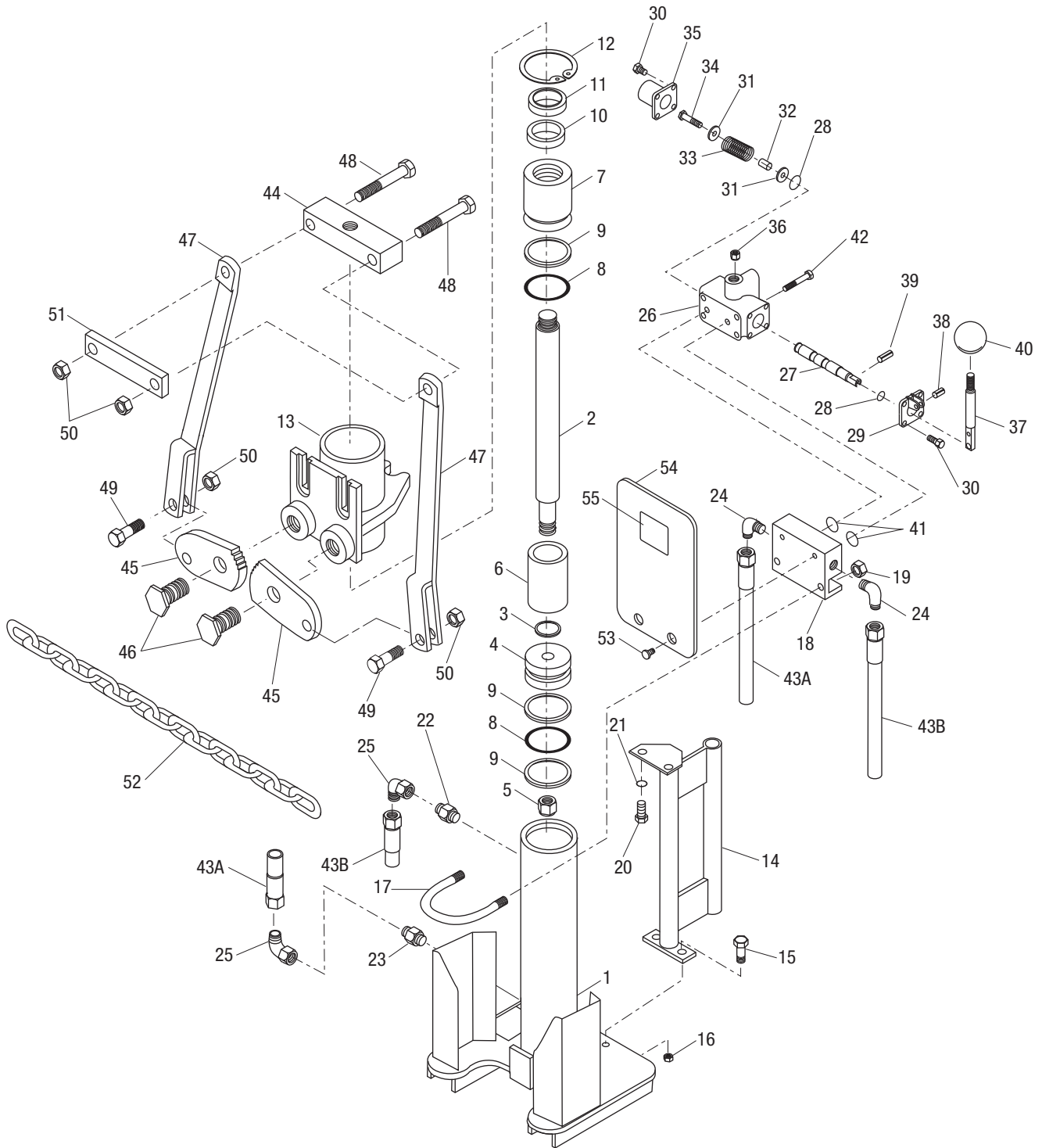

## Parts List

Key	UPC No. 78-3310-	Part No.	Description	Qty	Key	UPC No. 78-3310-	Part No.	Description	Qty
1	43847	50438476	Cylinder tube base .....	1	34			Shoulder bolt, .250 x 1.00 x #10-24 .....	1
2	43171	50431714	Cylinder rod .....	1	35	40257	50402572	Cap .....	1
3*			Seal, rubber, .726 x .062 x .075" .....	1	36	43787	50437879	Pipe plug, 1/4 M NPTF .....	1
4	43823	50438239	Piston.....	1	37	40469	50404691	Lever.....	1
5			Nut, hex, 5/8-18 lock .....	1	38			Roll pin, .187 x .750" .....	1
6	43849	50438492	Spacer, 1.505 x 2.25 x 3.19" .....	1	39			Roll pin, .250 x 1.00" .....	1
7	43824	50438247	Packing gland .....	1	40	41418	50414182	Control handle ball .....	1
8*			O-ring, 2.125 x 2.50 x .187"-70 .....	2	41*			O-ring, .562 x .750 x .093"-70 .....	2
9*			Backup ring, single turn, 2.138 x 2.506 x .075" .....	3	42			Screw, cap, 5/16-18 x 2.00" socket head .....	4
10*			Seal, U-cup, 1.50 x 2.00 x .375" .....	1	43A	40009	50400094	Hose, 5/16" I.D. x 14-1/2" length with 9/16-18 female JIC swivels at both ends .....	1
11*			Rod wiper, 1.500 x 1.875 x .281" .....	1	43B	40009	50400094	Hose, 5/16" I.D. x 14-1/2" length with 9/16-18 female JIC swivels at both ends .....	1
12	43825	50438255	Retaining ring, 2.625" internal .....	1	44	43848	50438484	Adapter.....	1
13	43838	50438387	Guide .....	1	45	41150	50411503	Jaw .....	2
14	40495	50404951	Handle .....	1	46	41081	50410813	Shoulder bolt, 7/8-14 x 1.781" .....	2
15			Screw, cap, 5/16-18 x 1.25" hex head .....	2	47	40498	50404980	Link.....	2
16			Nut, hex, 5/16-18 elastic stop.....	2	48			Screw, cap, 1/2-13 x 3.50" hex head.....	2
17	42055	50420552	U-bolt, 3/8-16 x 3.62" .....	1	49			Screw, cap, 1/2-13 x 1.75" hex head .....	2
18	43822	50438220	Junction block .....	1	50			Nut, hex, 1/2-13 lock .....	4
19			Nut, hex, 3/8-16 lock .....	2	51	43956	50439561	Bar .....	1
20			Screw, cap, 5/16-18 x .75" hex head .....	2	52	42014	50420144	Chain, 9/32 x 48" alloy steel.....	1
21			Washer, lock, .318 x .586 x .078" .....	2	53			Screw, cap, 1/4-20 x .750" flat head socket .....	2
22	41380	50413802	Adapter, 3/8 M NPTF x 9/16-18 M JIC .....	1	54	43094	50430947	Plate.....	1
23	41341	50413413	Adapter, 1/4 M NPTF x 9/16-18 M JIC .....	1	55	41547	50415471	Decal, Greenlee .....	1
24	41340	50413403	Elbow, 90°, 1/4 M NPTF x 9/16-18 M JIC .....	2	45691	50456911	Decal, warning.....	1	
25	41396	50413961	Elbow, 90° swivel, 9/16-18 M JIC x 9/16-18 F JIC .....	2	45690	50456903	Decal, flow/pressure/wt.....	1	
26	40255	50402553	Valve body .....	1	*	41173	50411732	Packing kit (includes items marked with an asterisk)	
27	43151	50431510	Spool .....	1	43846	52000932	Cylinder assembly (includes items 1-12).....	1	
28*			O-ring, .437 x .562 x .062-70 .....	2	40468	50404681	Valve (includes items 26-40) .....	1	
29	40258	50402582	Lever bracket.....	1					
30			Screw, cap, 1/4-20 x .500" socket head .....	8					
31	43429	50434292	Washer, flat, .265 x .734 x .059" .....	2					
32	43836	50438360	Spacer, .271 x .437 x .656" .....	1					
33	41663	50416631	Spring, compression, .576 x .720 x 1.75" .....	1					



4455 Boeing Drive • Rockford, IL 61109-2988 • USA • 815-397-7070  
©2019 Greenlee Tools, Inc. • An ISO 9001 Company

[www.greenlee.com](http://www.greenlee.com)

**USA** Tel: 800-435-0786  
Fax: 800-451-2632

**Canada** Tel: 800-435-0786  
Fax: 800-524-2853

**International** Tel: +1-815-397-7070  
Fax: +1-815-397-9247