

INSTRUCTION SHEET



Caster Installation for Models 3548, 5860, and MTS-100

50084267 fastener kit includes the following:

- 3/8-16 x 1 carriage bolt
- 3/8-16 hex nut
- 3/8 split lock washer

To install casters:

1. Position carriage bolts through square holes in bottom of box.
2. Mount casters from underside.
3. Put washers over bolts.
4. Thread nuts onto bolts.
5. Tighten nuts to approximately 20 foot-pounds.

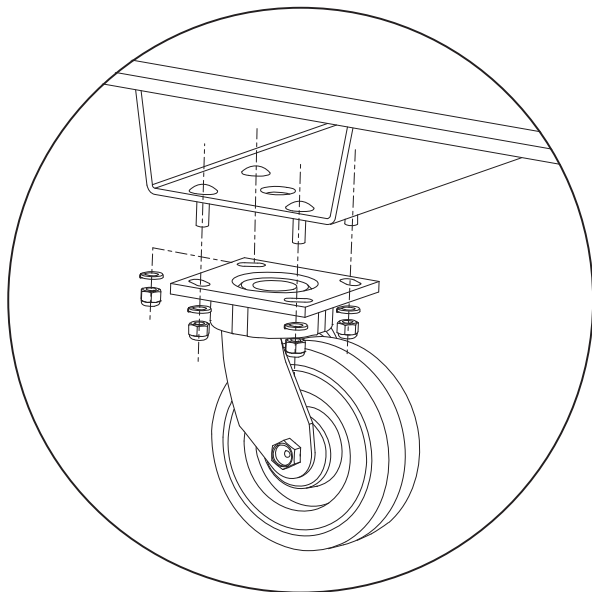

5860 Casters

NOTE: POSITION OF RIGID CASTERS

