

# SERVICE DATA SHEET



## 11077 Washer Kit for 881-MBT

### Description

The 11077 washer kit reinforces the 12" x 3" wheel used on the 881-MBT units that have the 52068627 wheel with six spokes. The instructions below describe the installation of the new components.

### Installation

1. Examine both 12" x 3" wheels to determine if a 2-7/16" OD washer is against both sides of the wheel and a 1-1/2" OD washer is against the retaining ring. If so, the wheel reinforcement is correct and no rework is required. See Figure 1.

### New Components

Key	Description	Qty
1	Thrust washer, 1.03 x 2.44 x .075 .....	4
2	Flat washer, .81 x 1.50 x .14 .....	4
3	Retaining ring, .75 EXT.....	2

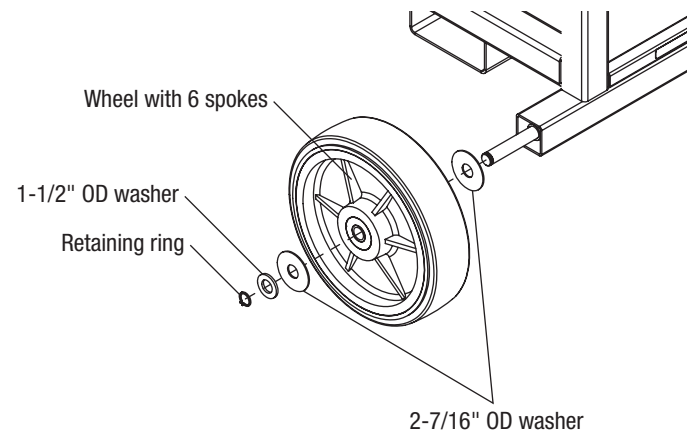

Wheel assembly is correct.  
No rework is required.

**Figure 1.**

**Installation (cont'd)**

2. If reinforcing washers are required, remove the accessories from the 881-MBT to reduce the weight. Remove items that could fall and become damaged.
3. Use a forklift or jack to safely raise the carriage just enough to lift the wheel off the floor.
4. Remove the retaining ring, washer(s), wheel, and sleeve.
5. Install the new washer (item 2A), thrust washer (item 1), sleeve, wheel, thrust washer (item 1), washer (item 2B) and retaining ring (item 3). If there is not enough space to install the retaining ring, remove the washer (item 2A) that is against the frame. See Figure 2 below.
6. Repeat the procedure for the second wheel.

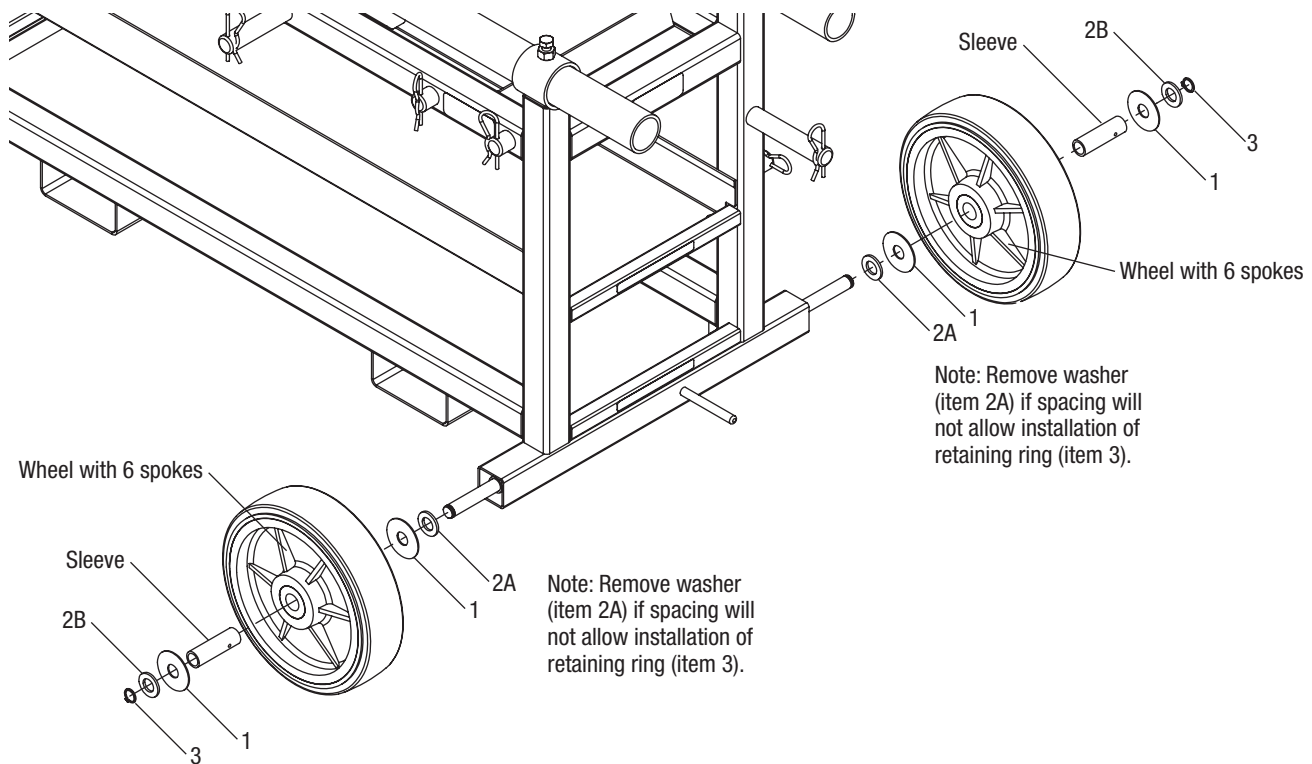
**Figure 2.**