

500XP

PRECISION FILTER PROBE

KEY FEATURES

- Power hum filter probe; updates 200FP and 200XP
- Ruggedized & water resistant case
- Bright LED signal strength indicators
- Hazardous AC voltage warning
- Powerful Loudspeaker
- Digital Signal Processing

OPERATION

Just two buttons are needed to control this probe. One button is the combined “power and gain down” control, the other for “gain up”. The indicator LEDs are also mounted behind this key.

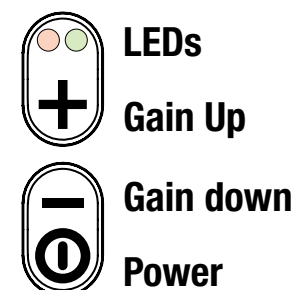

POWER ON AND OFF



Press the “power” button for half a second. At power on you should hear a beep with the red light (power up), release the button. A second higher pitched tone with the green LED lit indicates self-test OK.

Press the “power” button again for half a second and a lower pitch beep confirms power off.

ADJUST GAIN



A quick press of + or - will increase or decrease the gain. You should hear one beep with each press. The LEDs’ brightness is proportional to signal strength. **Use no more gain than necessary to reduce the risk of feedback.**

FILTER MODES

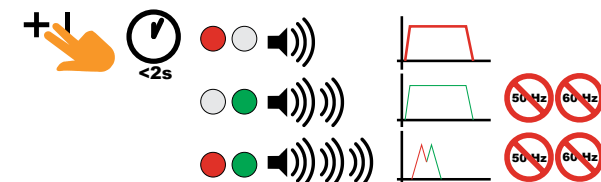

At switch on, the unit enters “standard” mode, similar to 200EP, all tones are audible, this is indicated by a single beep, as at power up, and the red light being flashed.

Quickly press both buttons together to step through the three “filter modes”.

The second mode, like 200FP, eliminates “power hum” harmonics but still receives all other tones, this is indicated by two beeps and the green light being flashed.

The third mode, like 200XP, eliminates “power hum” and also implements narrow band filters at 577 Hz and 983 Hz for virtually “noise free” pair tracing. Both LEDs are flashed.

Pressing both buttons again returns to “standard” mode.

HAZARDOUS AC WARNING

As 500XP is so effective at eliminating power hum from the signal we added acAlert™ which detects AC power in the range 45 to 65 Hz. Voltages above approximately 90 V AC near the tip will cause the probe to repeatedly sound a warning while rapidly flashing both LEDs.

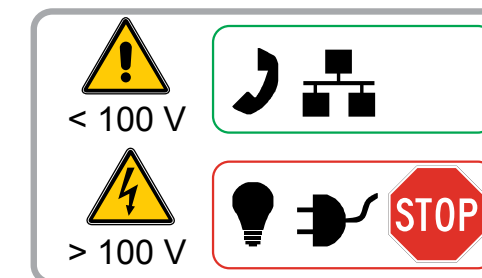

Should you hear such a tone, suspect that there may be a “power cross” or similar fault giving a possible risk of serious electric shock.

500XP should NOT be used to deliberately seek uninsulated “mains” power circuits. It is rated only for use in telecommunication networks and should NEVER be relied upon to prove a circuit is safe to touch. Greenlee can provide other products that are designed and rated for use in the power distribution network.

Refer to the manual which can be downloaded from Greenlee’s website for all safety information and additional instructions.

INSTALLING THE BATTERY

Only open the battery cover in clean and dry conditions; the battery terminals may be contaminated or corrode if dirt and moisture are present.

1. Loosen the two captive screws as indicated to the right.
2. Observing polarity, install a new alkaline 9 V battery. Check that the seal is clean and in place around the battery compartment.
3. Replace the cover and tighten (do not use excessive torque) the two screws, being careful not to cross-thread them.

If storing 500XP unused for a period greater than a month or so remove the battery to reduce the risk of damage due to leaking.

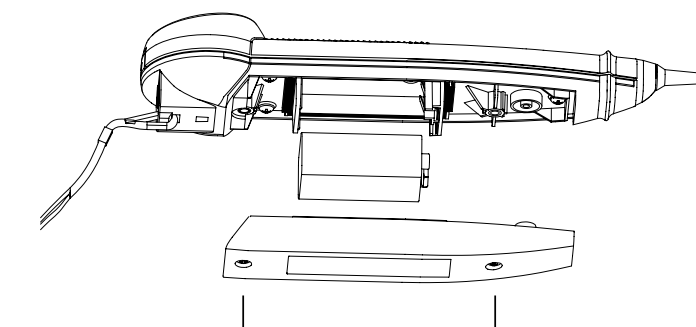

FILTER CONFIGURATION (SETUP)

Most people will not need to do this but the configuration of the filtering can be adjusted if needed. One example: If your test equipment uses precise 1000 Hz tones and you’re working in a 60 Hz power area you can disable the 50 Hz “power hum” filter. Otherwise you will not hear the 1000 Hz tone you’re seeking as it is the 20th harmonic of 50 Hz.

With the probe already operating, press and hold both buttons for ten seconds to enter “setup” mode. A short melody indicates entry to this mode followed by a number of beeps representing the current mode as listed below, this is replayed every few seconds.

Options selectable by pressing + or - are:

- 577 & 983 Hz filter with both 50 Hz and 60 Hz harmonic rejection (factory)
- 577 Hz filter with 60 Hz harmonic rejection
- 983 Hz filter with 50 Hz harmonic rejection
- 577 Hz filter with 50 Hz harmonic rejection
- 983 Hz filter with 60 Hz harmonic rejection

As each option is selected the corresponding number of beeps is generated. When the required mode is reached either wait twenty seconds or press and hold both buttons together for two seconds. A different melody is played as the chosen mode is saved in non-volatile memory.

Software Version Reporting: Following this a number of low pitch beeps and high pitch beeps are played representing the software version number; useful for technical support. For example boop-beep-beep represents V1.2.

Operation then continues as detailed overleaf. The filter mode can be changed again later as needed.

